



OVENS & COOKING BENCHTOP BEVERAGE DISPLAYS REFRIGERATION STAINLESS



Convenience Retail Equipment Guide

Convenience Retail Equipment Guide

Ovens & Cooking Equipment	3
Benchtop Equipment	9
Beverage & Ice Cream	13
Displays	20
Refrigeration	45
Stainless Steel & Benchware	65

Convection Oven

- Heavy-duty stainless steel build with easy-clean enamel interior
- 50–300°C range for baking, reheating and finishing hot snacks
- Dual reversing fans for fast, even cooking across all trays
- 60L capacity with 4 aluminium trays included
- Double-glass door with auto-stop safety function
- Compact 595mm width, 240V single phase (2.4kW)
- Choice of simple analogue or precision digital control



YXD-1AE



YXD-1DI



Code	Capacity(L)	Trays Included	External Dimensions (WxDxH mm)	Internal Dimensions (WxDxH mm)	Weight (kg)	Voltage	Power (kW/A)
Analogue Control							
YXD-1AE	60	4 x 437x314mm	595x530x579	460x375x360	35	240	2.4/10
Digital Control							
YXD-1DI	60	4 x 437x314mm	595x585x585	460x375x360	35	240	2.4/10

Convection Oven with Grill



YXD-3AE



YXD-3DI



PCB Control

- 62L capacity ideal for pies, pastries, hot snacks and ready-meals
- Dual round heaters with two high-speed motors for fast, even cooking
- Integrated grill function for finishing, browning and crisping products
- 120-minute timer with bell for controlled batch cooking
- 360°C safety high-limit thermostat for added protection
- Chamber light and double-glazed tempered glass for clear product visibility
- Four aluminium trays included with 75mm spacing for efficient airflow
- Rounded chamber corners and 90° door opening for easy cleaning and access
- Available in analogue control or digital control (YXD-3DI) for precise temperature management

Code	Capacity(L)	Trays	Dimensions (WxDxH mm)	Weight (kg)	Temperature Range	Voltage	Power (kW/A)
Analogue Control							
YXD-3AE	60	4 x 437x314mm	595x595x585	38	+50 to +300	240	2.4/10
Digital Control							
YXD-3DI	60	4 x 437x314mm	595x595x585	38	+50 to +260	240	2.4/10

Convection Oven



YXD-6A/15



YXD-6A on YXD-6A-S

- Stainless steel housing built for busy convenience store kitchens
- 99L capacity suits 4 x GN1/1 trays for higher volume batch cooking
- Ceramic coated cavity for easy cleaning and reduced build-up
- Fan-assisted top and bottom heating for even baking
- Integrated grill function for browning and finishing
- Cook & Hold function to maintain serving temperature
- 180-minute timer with bake reminder for controlled production
- Fan stops when door opens for added safety
- Waterproof on/off switch for durability
- Optional mobile stand with castors for flexible positioning

Code	Capacity(L)	Trays*	External Dimensions (WxDxH mm)	Internal Dimensions (WxDxH mm)	Weight (kg)	Voltage	Power (kW/A)
YXD-6A	99	4 x 1/1GN	798x662x596	550x418x431	64	240	2.2/10
YXD-6A/15	99	4 x 1/1GN	798x650x596	550x418x431	64	240	3.5/15
Stand							
YXD-6A-S		---	802x615x800	---	19	---	---

Convection Ovens with Digital Panel

- Stainless steel cooking chamber with rounded corners for fast, hygienic cleaning
- Temperature range 50°C–280°C ideal for bakery, snacks and ready-meals
- Double fan system for even baking across all trays
- Digital control panel with double display for precise operation
- Memory for up to 9 recipes for consistent results across staff
- 60-minute timer or continuous operation for flexible cooking
- Fan automatically stops when door is opened for safety
- Tempered low-E glass with internal halogen lighting for clear product visibility
- 84mm tray spacing (105mm on TDE-3BD) for efficient airflow
- Supplied with trays and fitted with non-slip feet for stable bench placement



TDE-3BD

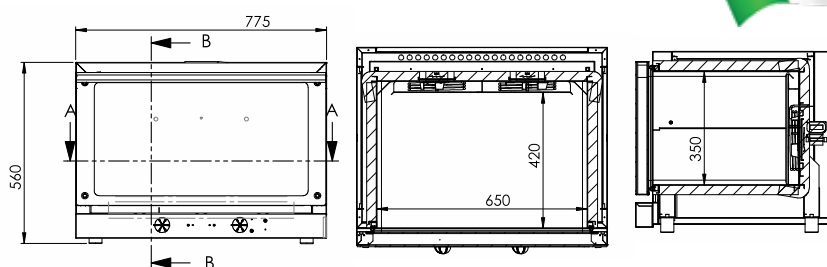

TDE-4CD

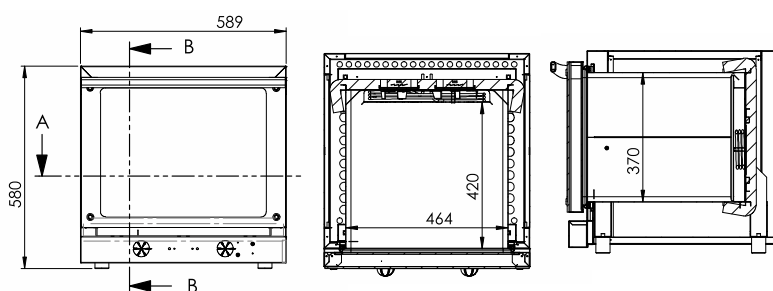

TDE-4CGND

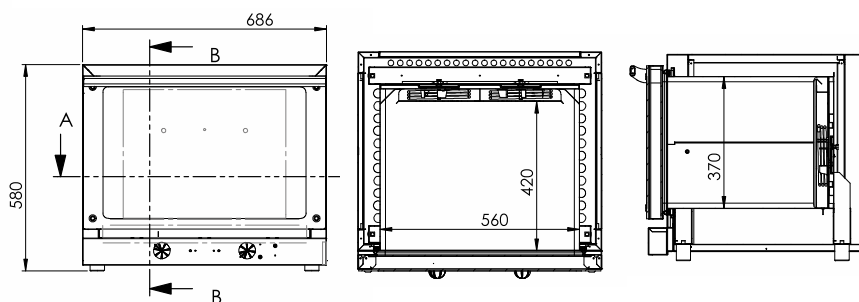

Code	Trays*	External Dimensions (WxDxH mm)	Internal Dimensions (WxDxH mm)	Weight (kg)	Voltage	Power (kW/A)
TDE-3BD	3 x 600x400mm	775x720x560	650x459x350	40	240	3.15/15
TDE-4CD	4 x 435x350mm	589x680x580	464x420x370	33	240	3.15/10
TDE-4CGND	4 x 1/1GN	686x663x580	560x420x370	37	240	3.15/15

Speed Oven

- Compact design with space-saving footprint, sleek appearance, and user-friendly operation
- 8.6L cooking chamber with up to 10-inch of cooking area
- Combines microwave and thermal radiation for faster, more even cooking
- 9 pre-set cooking programs
- Dual heating elements and microwave technology enable rapid cooking: Upper/lower heating elements ensure even browning, while microwave accelerates core heating, greatly reduce cooking time and enhance efficiency
- Features a 6.8-inch touchscreen with intuitive interface for precise control
- Stores 100+ programmable recipes, each customisable with 5-stage cooking programs with independent control of heating elements and microwave power
- Energy-saving mode maintains low-power standby during idle, reducing consumption and with instant recovery to cooking temperature
- Precise temperature setting range from 170°C - 240°C
- Equipped with a preheat function for added convenience
- For the Heat Radiation function, there are five cooking setting levels: Low, Medium, High, Strong, and Off. For Microwave cooking, the setting options are On or Off
- Triple-fan cooling for the magnetron and internal components—boosting reliability, extending lifespan, and keeping performance steady during extended use
- USB port enables recipe upload/download for centralised management

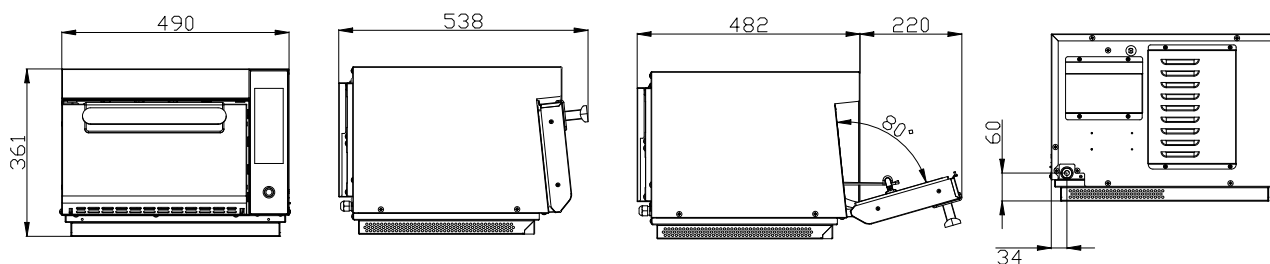

Code	Chamber cooking area volume capacity (L)	Dimensions (WxDxH mm)	Chamber cooking area size (WxDxH mm)	Temperature (°C)	Weight (kg)	Voltage	Power (kW/A)
NP-MWO-T	2.7	490x538x361	270x190x168	+170 to +240	43	240	3.3/15

Accessories

20101100022	Oven Shovel, 200x290mm suits NP-MWO-T
20101100018	Wire Shelf, suits NP-MWO-T
915020043	Enamelled Debris Collection Pan, suits NP-MWO-T
915010477	Stainless Steel Baking Pan 203x155x89mm, suits NP-MWO-T

- Stainless steel interior
- 5 inch Touch Screen for easy control
- Low power consumption
- High efficiency magnetrons for peak productivity and cooking while retaining moisture
- Multipurpose unit combining microwave & hot air impingement
- Built-in oil, smoke filter and catalytic converter
- Easy to clean, maintain & operate
- Pre-set menus and manual settings, store up to 1024 menus
- 15 Cooking Stage
- Cooking Modes: Vertical hot air impingement, Microwave & convection
- Microwave Output Range: 0-100%, in 10% increment
- Variable setting to suit frozen or chilled food
- IPX3 Waterproof Rating
- 10 Blower Speed with Timer and USB Port
- NP-ProSiT Comes with Round Pizza Pan, Oven Shovel, and Inner Hall Grill
- NP-ProBTD comes with tray and shovel



Code	Capacity (L)	Dimensions (WxDxH mm)	Chamber Size (WxDxH mm)	Temperature (°C)	Weight (kg)	Voltage	Power (kW/A)
NP-ProSiT	17	460x675x660	305x305x185	Max 280	64	240	3.5/15
NP-ProBTD	17	460x677x660	317x294x193	Max 280	81	415	6.3/3~N
Accessories							
20101060199	Oven Shovel, 270x290mm, suits NP-ProSiT, NP-ProBTD						
907010003	Pizza Pan, 270x290mm, suits NP-ProSiT						
907010037	Inner Hall Grill, 343x312x25mm, suits NP-ProSiT						
907010146	Metal Tray, suits NP-ProBTD						

1000W - Light Duty Commercial Microwave



- Large capacity (0.9 cu.ft / 25 L), accommodates a 12" (305 mm) platter
- Stainless steel cabinet and oven cavity
- 5 power levels and 3 cooking stages
- Bottom energy feed
- 60 minute maximum cooking time and 100 auto programs
- Time entry option and X2 multiple quantity pad provide flexible operation
- Oven cavity light to monitor cooking status without opening the door
- Easy Grab & Go door handle for reliable use, no moving parts
- User-friendly touch control pads and Electronic dial timer with braille navigation



Code	External Dimensions (WxDxH mm)	Internal Dimensions (WxDxH mm)	Weight (kg)	Voltage	Power (W/A)
MD-1000L	511x432x380	327x346x200	14.7	240	1000/10

1400 Watt - Performance Commercial Microwave

- Large capacity (1.2 cu.ft / 34 L), accommodates a 14" (356 mm) platter
- Able to withstand the demands of the Commercial Food Service environment with stainless steel cabinet and oven cavity
- Bottom energy feed
- 5 power levels and 3 cooking stages for different cooking demands
- 60 minutes maximum cooking time and 100 auto programs can cover most product demands
- Time entry option and X2 multiple quantity pad provide flexible operation
- Oven cavity light to monitor cooking status without opening the door
- Easy Grab & Go door handle for reliable use, no moving parts
- User-friendly touch control pads and Electronic dial timer with braille navigation
- Stackable



Code	External Dimensions (WxDxH mm)	Internal Dimensions (WxDxH mm)	Weight (kg)	Voltage	Power (W/A)
MD-1400	553x488x343	370x385x230	18.4	240	1400/10

Commercial Benchtop Food Warming Display Cabinet



- Stainless steel base built for busy convenience store counters
- Adjustable shelving to suit pies, pastries, rolls and hot snacks
- Available in 3 or 4 tier configurations for flexible product display
- Clear glass panels for strong visibility from multiple angles
- LED lighting enhances product appeal while remaining energy efficient
- Digital temperature control for consistent holding between 30–70°C
- Front ventilation maintains stable internal temperature
- Compact, space-efficient design ideal for petrol stations and small supermarkets
- Modern black finish to complement contemporary store fit-outs



HD-205



HD-318

Code	Litre	Dimensions (WxDxH mm)	Weight (kg)	Temperature Range °C	Voltage	Power (W/A)
HD-205	205	740x650x850	65	30-70	240	850/10
HD-318	318	800x575x967	75	30-60	240	850/10

Backfill Heated Display Cabinet

This unit is crafted for commercial environments, enabling effortless control with a mechanical controller and clear temperature display. The specialized stainless steel guide is designed to ensure a smooth transition of food from the back to the front for service.

- **Dual-Tier Shelves:** Organises and displays products effectively
- **Stainless Steel Food Slide Guide:** Regulates the descent of food from the back
- **Stainless Steel Accents:** Offers a sleek and clean appearance
- **Glass Visibility:** Full transparency for viewing from any angle
- **Mechanical Temperature Control:** For hands-on, reliable adjustments
- **Visible Temperature Display:** Allows for easy monitoring of heat levels
- **Contemporary Black Design:** Fits seamlessly into modern settings
- **Robust Leg Supports:** Provides stability and proper elevation



HWB2-65



HWB2-102



HWB2-138



HWB2-152

Code	Capacity (m ²)	Dimensions (WxDxH mm)	Weight (kg)	Temperature Range °C	Voltage	Power (W/A)
HWB2-65	0.65	600x703x704	34	+30 to +85	240	900/10
HWB2-102	1.02	953x703x704	50	+30 to +85	240	1100/10
HWB2-138	1.38	1259x703x704	63.5	+30 to +85	240	1880/10
HWB2-152	1.52	1400x703x704	86	+30 to +85	240	1880/10

Digitally Controlled Pie/Food Warmer



Our HUMIDIFIED Food Warmer is the ultimate solution for showcasing and preserving the quality of your culinary creations. Designed for versatility and optimal display, this state-of-the-art food warmer combines cutting-edge technology with sleek aesthetics to meet the needs of restaurants, bakeries, cafes, and catering services seeking to make a lasting impression.

- Digital control ranges from 30°C to 90°C for accurate temperature
- Advanced humidity control maintains 30% to 80% humidity to keep food moist
- Toughened glass display with durable 4-sided glass for enhanced visibility and safety
- Customisable shelving – selection between fixed or rotating shelves for optimal display
- Single door access, optional pass-through models available on request
- 304 Stainless steel shelving
- 4 x LED lighting on door frames illuminates displays, enhancing product visibility and appeal



HWD-158



HWD-158/R

Code	Capacity (L)	Dimensions (WxDxH mm)	Weight (kg)	Temperature Range °C	Voltage	Power (W/A)
HWD-158	158	570x631x826	41	+30 to +90	240	1300/10
HWD-158/R	158	570x631x826	41	+30 to +90	240	1300/10

Countertop Self-Serve Heated Food Displays

- Mechanical adjustable temperature control for simple, reliable operation
- Five sides of glass for maximum product visibility on counter
- Straight glass design for clean, modern store presentation
- Chrome plated shelves for durable, easy-to-clean display
- Front and rear hinged doors for easy staff access and restocking
- LED side lighting (80L & 115L models) to enhance product appeal
- Compact benchtop design ideal for convenience stores and service stations

HSW-50

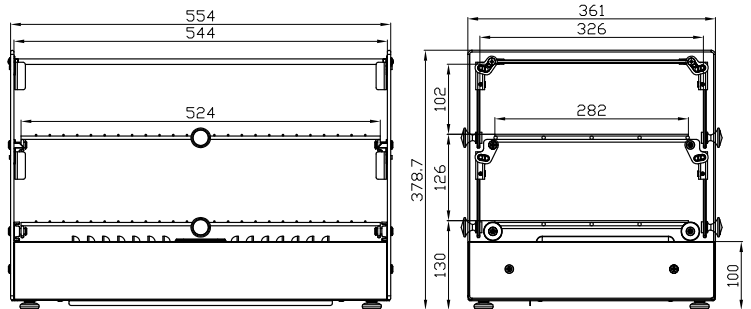

HSW-80L

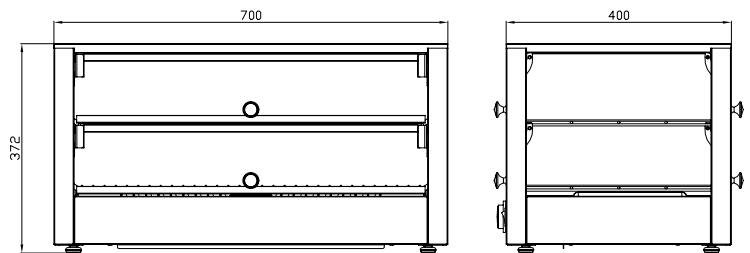

HSW-115L

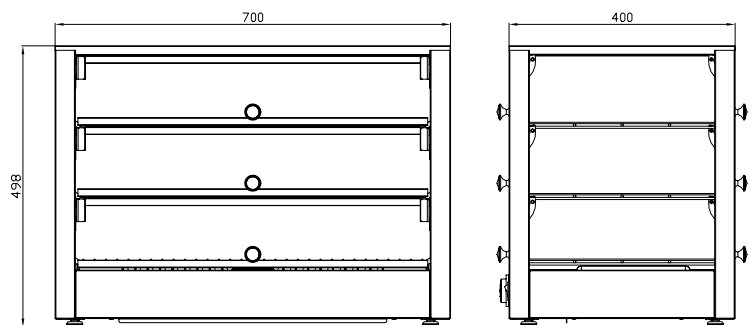

Code	Shelves	Litre	Dimensions (WxDxH mm)	Weight (kg)	Temperature Range °C	Voltage	Power (W/A)
HSW-50	1	50	555x361x379	14	+30 to +90	240	800/10
HSW-80L	1	80	700x400x372	16.5	+30 to +90	240	1100/10
HSW-115L	2	115	700x400x500	19.5	+30 to +90	240	1100/10

Heated Pie Cabinets



- Stainless steel interior for easy cleaning and long service life
- Thermostatic temperature control from 30–110°C for reliable holding
- Multiple grid levels to maximise pie and pastry capacity
- Glass sliding doors for quick access and smooth service
- Integrated advertising lightbox to promote products and boost impulse sales
- Removable humidity basin to help maintain product freshness
- Halogen lighting to enhance product presentation on counter
- Compact footprint ideal for convenience stores and petrol stations

PW-RT/380/TGE

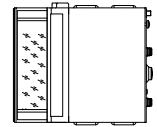
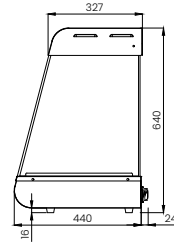
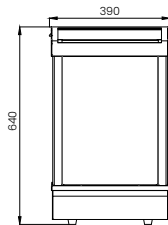

PW-RT/660/TGE

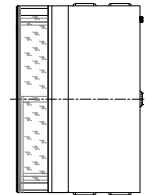
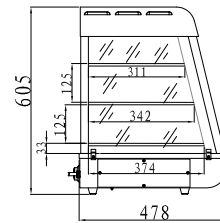
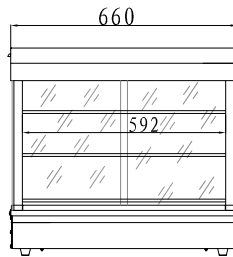

PW-RT/900/1E

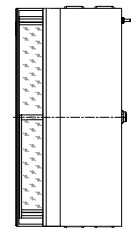
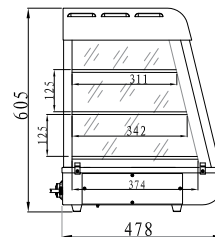
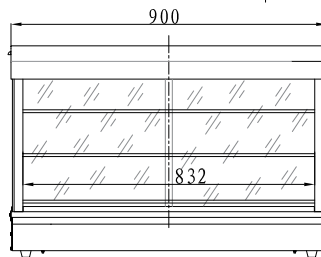

PW-RT/1200/1E

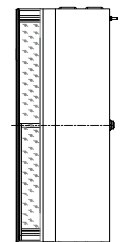
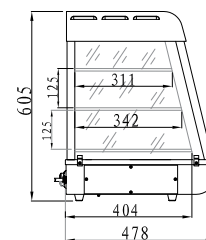
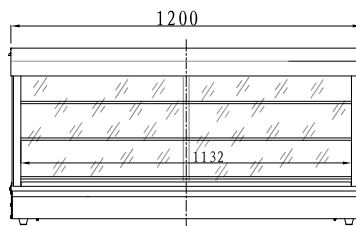

Code	No. Pies	Dimensions (WxDxH mm)	Weight (kg)	Temperature Range °C	Voltage	Power (kW/A)
2 Shelf – extra shelves available on request						
PW-RT/380/TGE	40	390x464x640	33	+30 to +110	240	1.2/10
3 Shelf						
PW-RT/660/TGE	60	660x478x605	37	+30 to +110	240	1.84/10
PW-RT/900/1E	90	900x478x605	50	+30 to +110	240	1.84/10
PW-RT/1200/1E	100	1200x482x797	72	+30 to +110	240	2.2/15

Heated Pie Cabinets



- All stainless steel construction for durability and easy cleaning
- Toughened glass front and rear for safe, clear display
- Thermostat controlled heating 30–80°C with temperature display
- Adjustable shelves to suit pies and hot snacks
- Sliding glass doors for easy access and restocking
- Removable crumb tray for simple maintenance
- Anti-slip rubber feet for stable benchtop use



Code	No. Pies	Dimensions (WxDxH mm)	Weight (kg)	Temperature Range °C	Voltage	Power (kW/A)
4 Shelves – 569x300mm						
DH-580E	60	640x360x526	21	+30 to +80	240	1.0/10
5 Shelves – 794x300mm						
DH-805E	100	865x360x621	35	+30 to +80	240	1.5/10

Slushy & Granita Machines



- DC brushless motor with torque control to protect auger
- Auto shut off safety protection
- Handles low-sugar mixes from 8% Brix
- Fast 2 hour granita preparation time
- Polycarbonate containers for durability and visibility
- Performance temperature -2°C to -4°C
- Low noise operation at 70dB
- Easy to clean design



Code	Dimensions (WxDxH mm)	Weight (kg)	Voltage	Power (W/A)
Single Bowl - 1x 12L				
FABIGANI-1S	270x515x810	31	240	400/10
Double Bowl - 2x 12L				
FABIGANI-2S	470x515x810	59	240	740/10
Triple Bowl - 3x 12L				
FABIGANI-3S	670x515x810	137	240	1150/10

Heated units are for hot food holding only, not designed to heat product. Prices and specifications are subject to change without notice. Pictures are for illustrative purpose and final product may differ

Automatic Coffee Machine

- Automatic machine perfect for hotels, pubs, clubs and small offices
- Dual bean hoppers and commercial grinders allow two coffee blends, delivering consistent espresso quality across every cup
- Fresh hot and cold milk with automatic frothing expands your menu with café-style beverages at the touch of a button
- Dual pumps and boilers enable simultaneous brewing and steaming, reducing wait times during peak periods
- Recommended for up to 200 cups per day, ideal for pubs, clubs, gaming lounges and office environments
- Automatic milk system cleaning minimises staff intervention and maintains hygiene standards
- 10.1" touchscreen interface offers intuitive drink selection and simple daily operation
- Lockable ingredient canisters protect stock and support controlled commercial use
- Optional SaaS remote monitoring helps track performance, usage and maintenance across multi-site venues



Code	Dimensions (WxDxH mm)	Weight (kg)	Interface	Spout Height (mm)	Water Supply	Voltage	Power (kW/A)
JAC-38A	312 x 695 x 608	38	10.1" Touchscreen	80-180	Barreled water/ tap water, opt. 8L built-in tank	240	3.1/15

Drink Dispenser - Paddle Action



- 12L removable food-grade polycarbonate bowl for easy refilling, cleaning and flavour changeovers
- Paddle action stirring system keeps juice with pulp and milk-based drinks evenly mixed
- Stainless steel construction for durability in high-traffic convenience stores
- Compact benchtop design ideal for petrol stations and small supermarkets
- Available in single, double or triple bowl configurations to suit demand
- Clear bowls maximise product visibility and encourage impulse purchases
- Reliable cooling performance to maintain consistent serving temperature
- Simple controls for easy staff operation across all shifts
- Removable drip tray for quick cleaning and hygiene control
- Designed for daily beverage service including juices, flavoured drinks and dairy blends



KF12L-3



KF12L-1



KF12L-2

Code	Dimensions (WxDxH mm)	Weight (kg)	Voltage	Power (kW/A)
Single Bowl - 1x 12L				
KF12L-1	410x350x660	22	240	250/10
Double Bowl - 2x 12L				
KF12L-2	410x410x660	28	240	320/10
Triple Bowl - 3x 12L				
KF12L-3	600x410x660	36	240	380/10

Digital Commercial Blender with Sound Cover



- Japanese tungsten blades offer exceptional durability and sharpness to give you precise and efficient blending
- 2-litre jug to accommodate large batches of ingredients
- Simplifies operation with a large LCD display and preset blending programs, allowing you to achieve your desired textures and consistencies with a single touch
- Auto shut off enhances safety by automatically turning off the blender after blending is complete, preventing over-blending and conserving energy
- Comes standard with sound cover to reduce operational noise during blending
- With sound cover, noise level between 72-74dB
- Without sound cover, noise level between 86-90dB
- The KS10000 provides an effortless blending experience with its advanced features, ensuring smooth, convenient, and safe operation for all your blending needs



Code	Speed (RPM)	Dimensions (WxDxH mm)	Weight (kg)	Voltage	Power (kW/A)
2L Digital blender with sound cover					
KS-10000	25000~28000	342x290x588	8	240	1.5/10
Spare Jug Assembly					
KS-10000-J	2L jug assembly, comes with blade set. BPA free				

Gelato / Ice Cream Displays



- Illuminated front panel to boost brand visibility and impulse sales
- 4mm curved glass canopy with sliding doors for easy service
- Static cooling system for consistent temperature control
- Natural eco-friendly refrigerant for energy efficient operation
- Stainless steel 5L pans included ready for service
- Steel inner-body construction for durability
- Lock and key for added product security
- Mounted on 75mm castors for easy repositioning
- Class 4+ climate rating for reliable performance

SD-325P

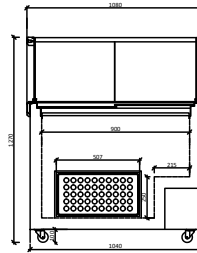
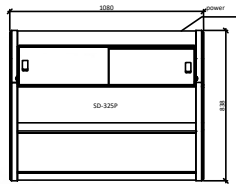

SD-415P

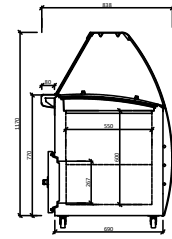
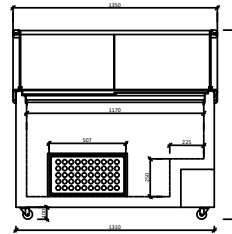
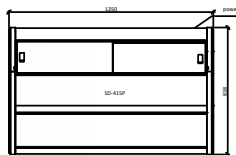

Side Drawing

SD-575P

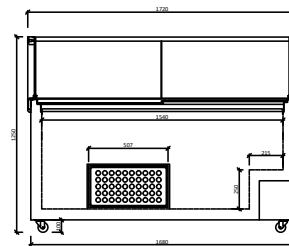
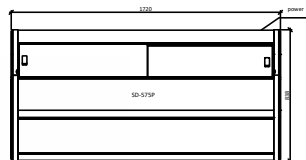

Code	GEMS Star Rating	Dimensions (WxDxH mm)	Pans	Capacity (L)	Weight (kg)	Temperature Range (°C)	Ambient / RH%	Voltage (V)	Power (W/A)
SD-325P	8	1080x838x1270	6 x 5L	300	109	-22 to -18	30 / 55	240	280/10
SD-415P	9	1350x838x1270	9 x 5L	400	123	-22 to -18	30 / 55	240	310/10
SD-575P	8	1720x838x1270	12 x 5L	535	152	-22 to -18	30 / 55	240	420/10
Gelato-5L (pan)	-	360x165x120	-	5	-	-	-	-	-

Heavy Duty Supermarket Glass Sliding Lid Freezers



- Curved glass design for elegant visibility and enhanced product display
- 70mm insulation for optimal temperature retention and energy efficiency
- Analogue temperature controller for precise and user-friendly operation
- Heavy-duty basket included for organised storage and easy access to products
- Designed for performance in Climate Class 7 conditions, ensuring reliability in extreme temperatures
- Utilises eco-friendly R290 gas, minimising environmental impact
- Durable ABS frame construction for long-lasting use and stability
- Perfect for ice cream display and storage, showcasing products
- Static cooling unit, maintaining consistent temperatures
- Manual defrost required, allowing for maintenance and cleaning control
- Lock for added security
- Heavy-duty castors for easy mobility and positioning



SD-306K



SD-406K



SD-506K



SD-576K



SD-666K



Side view

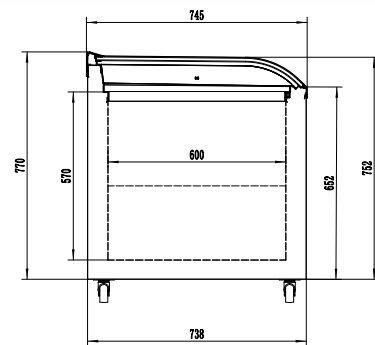

Code	Gross Capacity (L)	Baskets	Dimensions (WxDxH mm)	Weight (kg)	Temperature Range	Ambient/ RH%	Voltage	Power (W/A)
SD-306K	303	4	1006x745x845	63	-22 to -18	35/75	240	180/10
SD-406K	386	5	1216x745x845	72	-22 to -18	35/75	240	180/10
SD-506K	477	6	1446x745x845	81	-22 to -18	35/75	240	230/10
SD-576K	561	7	1656x745x845	91	-22 to -18	35/75	240	255/10
SD-666K	636	8	1894x775x890	102	-22 to -18	35/75	240	255/10

Gelato/ Ice Cream Display Showcase



- The Bonvue gelato display freezer is designed for efficient, quiet operation with a focus on premium presentation and sustainability.
- High-efficiency insulation maximises energy savings
- Standard gelato pan compatibility (not included)
- Whisper-quiet operation
- LED display lighting showcases gelato
- Heated, anti-fog glass ensures clear visibility
- Mirror finish interior – 304 stainless steel for elegance and ease of maintenance
- Dual vent cooling system ensures uniform cooling
- Eco-Friendly R290 refrigerant reduces environmental impact
- Stable Temperature Range: -16°C to -18°C.
- Self-defrost system streamlines maintenance
- White colour available on demand

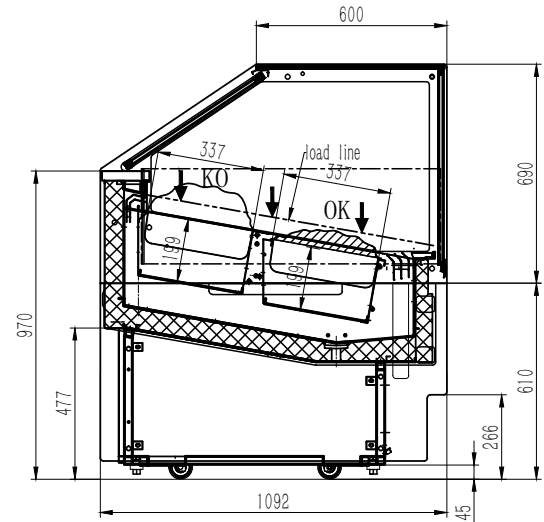

SGD-12B



SGD-18B



Code	Pans	Dimensions (WxDxH mm)	Weight (kg)	Temperature Range °C	Ambient/RH%	Voltage	Power (W/A)
SGD-12B	12 x 5L	1233x1095x1300	290	-18 to -16	30/55	240	1350/10
SGD-18B	18 x 5L	1728x1095x1300	455	-18 to -16	30/55	240	1650/10
SGD-24B	24 x 5L	2310x1095x1300	580	-18 to -16	30/55	240	2212/15
GELATO-5L	-	360x165x120	-	-	-	-	-

Designed for style and practicality, this counter top / serve over display keeps food at the perfect serving temperature while showcasing products attractively. The double-glazed glass and LED lighting enhance presentation, while easy-access sliding doors and sturdy stainless steel construction ensure durability and convenience.

- Two adjustable shelves plus base display area
- Durable stainless steel construction
- Double-glazed glass for superior insulation and clarity
- Digital temperature controller
- Bright, energy-efficient interior LED lighting
- Rear sliding doors for easy access
- Self-contained eco-friendly natural refrigeration system (refrigerated models)
- Integrated heating element for heated models

GN-660RT/ GN-660HRT

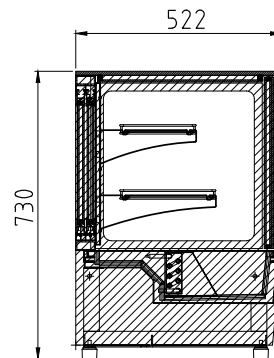
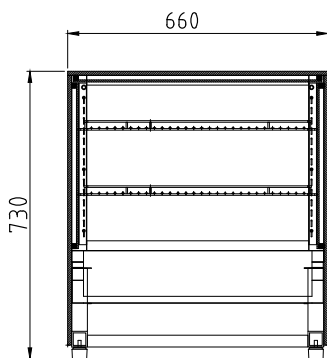

GN-900RT/ GN-900HRT

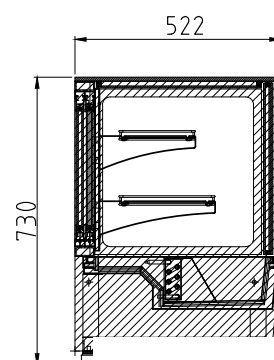
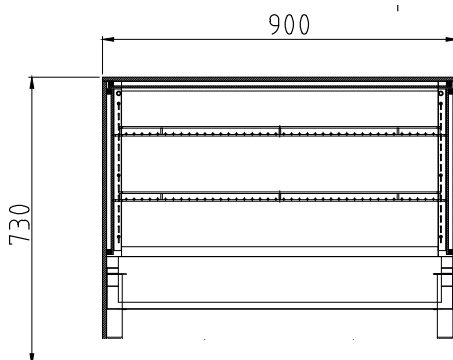

GN-1200RT

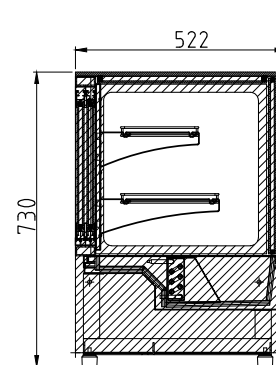
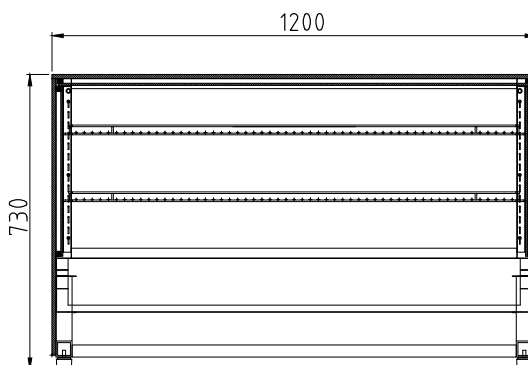

Code	GEMS Star Rating	Gross Capacity (L)	Dimensions (WxDxH mm)	Weight (kg)	Temperature Range °C	Ambient/ RH%	Voltage	Power (W/A)
Chilled Displays								
GN-660RT	7	68	660x530x730	66	+2 to +8	25/65	240	210/10
GN-900RT	6	93	900x530x730	75	+2 to +8	25/65	240	260/10
GN-1200RT	6	127	1200x530x730	113	+2 to +8	25/65	240	280/10
Heated Displays								
GN-660HRT	-	68	660x530x730	45	+40 to +65	--	240	520/10
GN-900HRT	-	93	900x530x730	75	+40 to +65	--	240	540/10

This counter top display unit stands out in the market with its significantly larger display area and an extra shelf, allowing businesses to showcase a greater variety of products prominently.

- **Eco-Friendly Efficiency:** Utilises natural R290 refrigerant, with an exceptional 9 or 10-star GEMS energy rating
- **Enhanced Product Showcase:** Offers a larger display area than competitors, featuring an additional shelf for more display space

- **Bright LED Lighting:** Dual-sided LED lights create an attractive presentation of contents
- **Precision Temperature Control:** Digital temperature controller for accurate adjustments
- **Extra Shelving Advantage:** Comes with three adjustable chrome-plated shelves, maximizing display variety
- **Robust Glass Insulation:** All sides encased in double tempered glass for safety and thermal efficiency
- **Reliable Cooling System:** Ventilated cooling ensures a consistently chilled environment
- **Automatic Defrost Function:** Streamlines upkeep by preventing ice build-up
- **Effective Condensation Removal:** Three-side airducts adeptly manage moisture, keeping the view unobstructed
- **Convenient Access:** Rear sliding doors provide smooth restocking and service

CTA-146

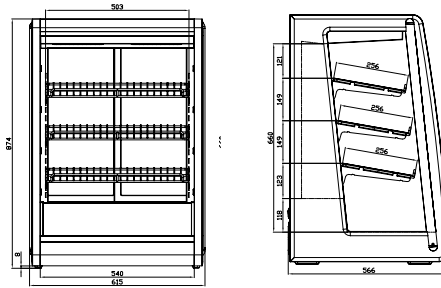

CTA-196

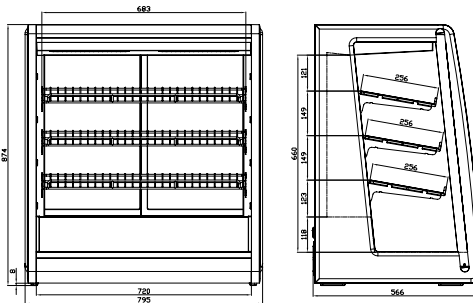

CTA-246

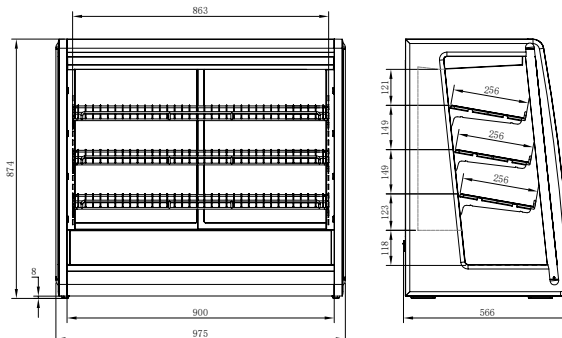

Code	GEMS Star Rating	Gross Capacity (L)	Dimensions (WxDxH mm)	Weight (kg)	Temperature Range °C	Ambient/ RH%	Voltage	Power (W/A)
CTA-146	9	146	615x560x874	55	2 to +12	30/55	240	200/10
CTA-196	10	196	795x560x874	64	2 to +12	30/55	240	200/10
CTA-246	10	246	975x560x874	76	2 to +12	30/55	240	215/10

Elegant Ambient Benchtop Display

ADS-150



- Comes fully assembled
- 2 hinged doors at back
- LED on top and under shelf
- Double shelves with bamboo mats
- Stainless steel frame construction with straight tempered glass

Code	Capacity (L)	Dimensions (WxDxH mm)	Weight (kg)
ADS-150	150	988x457x516	35

ADG-60



- Easy to assemble
- Full stainless steel base
- Hygienic and easy to maintain
- Hinged door at front or at back
- Tempered glass shelves

Code	Capacity (L)	Dimensions (WxDxH mm)	Weight (kg)
ADG-60	60	406x340x618	17
ADG-70	70	361x605x514	13

ADG-70



ADB-318



- All sides single-tempered glass
- Hinged doors at back
- 4 chrome plated shelves
- Front straight glass
- Accessories drawer at base
- Sleek black finish

Code	Capacity (L)	Dimensions (WxDxH mm)	Weight (kg)
ADB-318	318	800x575x967	52

Ambient Showcase Display



Transform your countertop into a showcase of sophistication with the Bonvue Ambient Display Unit. Expertly designed for premium display, this unit combines the best of practicality and aesthetics to enhance your customer's experience.

- Elevate your countertop with the Bonvue Ambient Display Unit, a blend of sleek design and practicality
- Elegant Design: Enhances any countertop with its modern, sophisticated look
- Toughened Glass: Offers durability and a clear view of the display items
- Sliding Doors: Ensure easy and quick access to the contents
- Perfect for cafes, bakeries, or delis, the Bonvue Display Unit is the hassle-free choice for a superior product presentation



AD1-900



AD1-1200



AD2-550



AD2-830



AD2-900

Code	Gross Capacity (L)	Dimensions (WxDxH mm)	Weight (kg)
Single Layer			
AD1-900	48	920×330×200	14.5
AD1-1200	68	1200×330×200	18
Double Layer			
AD2-550	65	550×398×381	17
AD2-830	90	827×368×366	21.5
AD2-900	120	920×398×381	26

Bonvue Deluxe Cold Display



Bonvue refrigerated display cabinet is a product of strong practicality and superior quality, meticulously crafted and designed for the display of pastries, drinks, cakes, fruits, and dairy products. Bonvue stands as one of the leading brands in the multi-functional kitchen utensils and display stand sector. This refrigerated display unit, with its solid construction, is a practical choice for any cake shop or café.



- Three levels of adjustable glass shelving plus floor
- 20kg weight limit per shelf
- Flush sides, perfect for two units joined together
- Cold white LED lighting over each level for enhanced display
- Fan-forced cooling system with self-evaporating drainage system
- 360° unobstructed display
- Overflow water tray to overcome extreme humidity and heat
- Digital temperature control
- Sliding rear doors made of tempered glass for easy access (swing door for SF820V)
- Castors with lock down bolt for easy positioning and levelling
- Natural and eco-friendly refrigerant
- Stainless steel machine base for durability and ease of cleaning
- Tempered ITO heated front, top and sides glass
- Removable condenser filter for easy cleaning
- Rodent mesh included



Code	GEMS Star Rating	Dimensions (WxDxH mm)	Weight (kg)	Temperature Range °C	Ambient/ RH%	Voltage	Power (W/A)
Chilled Displays							
SF820V	4	600x767x1350	128	+2 to +8	32/60	240	660/10
SF830V	4	900x740x1350	166	+2 to +8	32/60	240	845/10
SF840V	4	1200x740x1350	190	+2 to +8	32/60	240	1146/10
SF850V	4	1500x740x1350	236	+2 to +8	32/60	240	1380/10
SF860V	4	1800x740x1350	256	+2 to +8	32/60	240	1422/10

Bonvue Deluxe Cold Display



SF820V

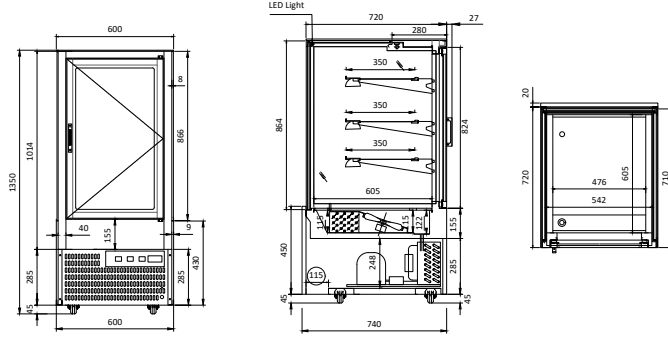

SF830V

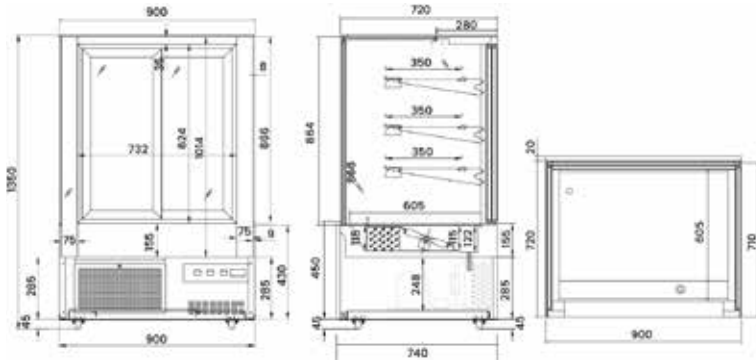

SF840V

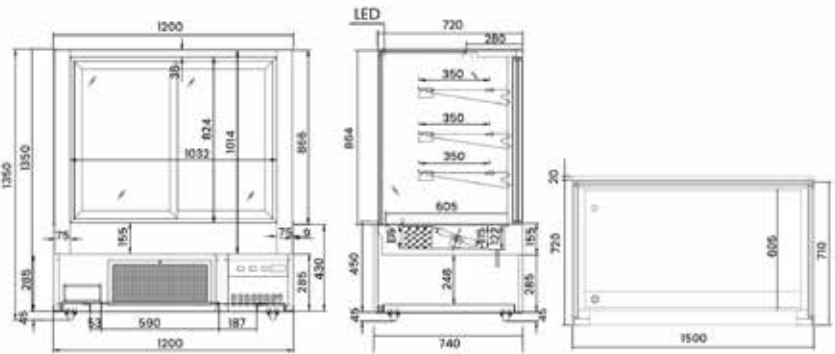

SF850V

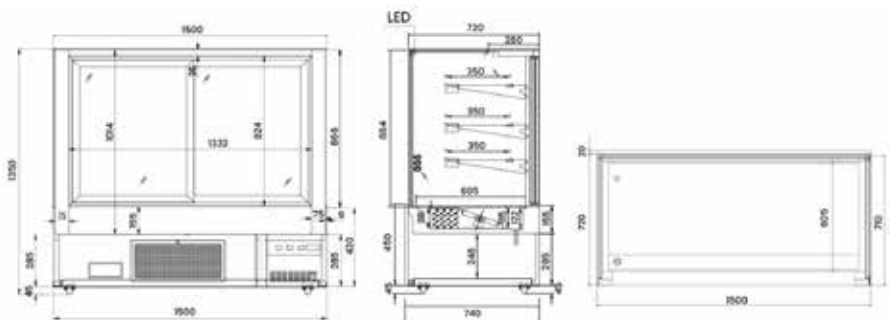

SF860V

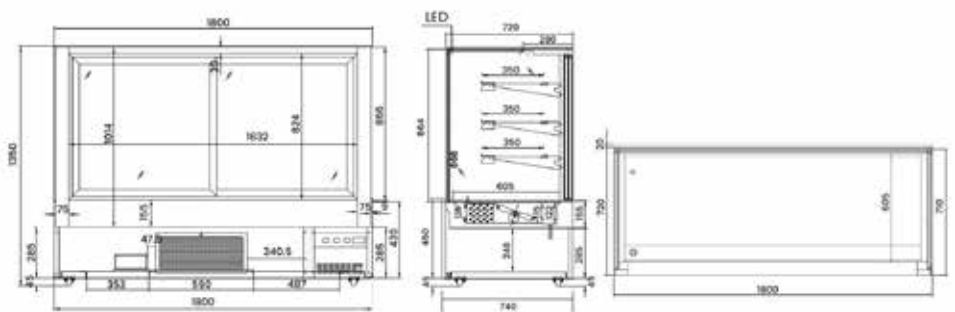

Bonvue Deluxe Heated Display Cabinet



Heated Display Cabinet combines robust construction with advanced functionality for food businesses. Featuring 4-sided tempered glass and AISI304 base display area, it ensures durability and hygiene. The 360° panoramic display with warm yellow LED lighting enhances product visibility, while the temperature control maintains optimal heating. Ideal for bakeries and cafés, its sliding rear doors and mobility-ready design offer effortless access and positioning. Energy-efficient with uniform heat distribution.



- Three levels of shelving plus floor
- 20kg weight limit per shelf
- Flush sides, perfect for two units joined together
- Tempered glass on all 4 sides
- Warm LED lighting on each level
- 360° unobstructed panoramic display
- Temperature control
- Tempered glass sliding rear doors for easy access
- Castors with lock down bolt for easy positioning and levelling
- Fan-forced element heating for consistent temperature



Code	Dimensions (WxDxH mm)	Weight (kg)	Temperature Range °C	Voltage	Power (W/A)
Heated Displays					
H-SF820V	600x767x1350	140	+30 to +85	240	786/10
H-SF830V	900x740x1350	170	+30 to +85	240	1044/10
H-SF840V	1200x740x1350	200	+30 to +85	240	1314/10

Bonvue Deluxe Heated Display Cabinet



H-SF820V

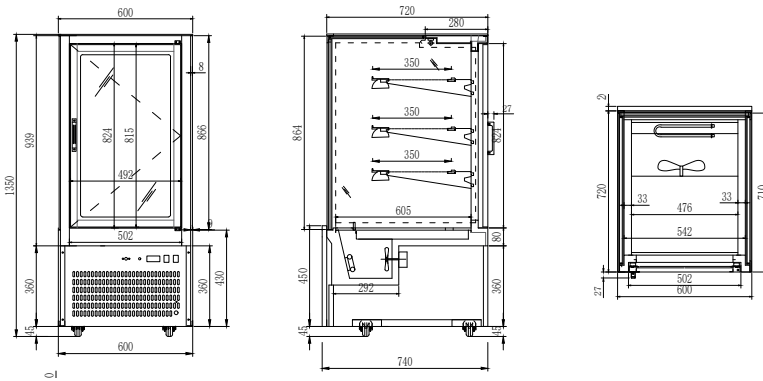

H-SF830V

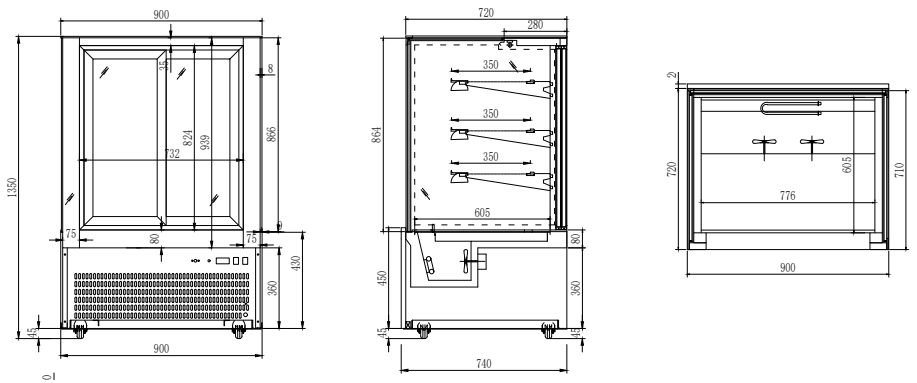

H-SF840V

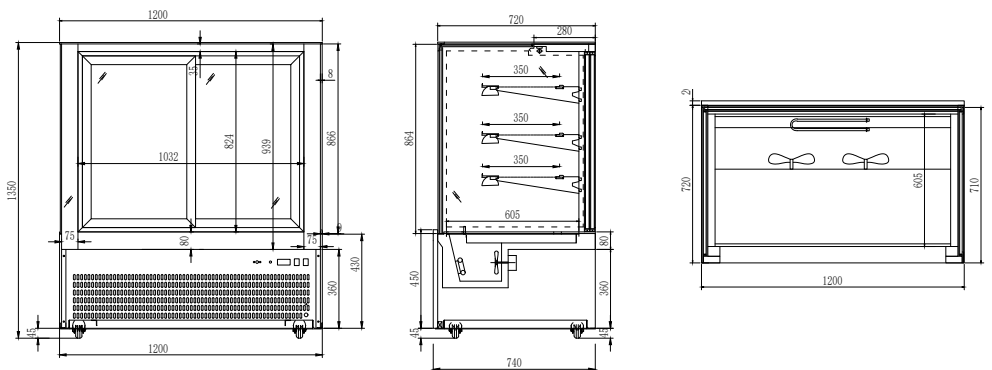

- Three adjustable levels of shelving plus floor
- 20kg weight limit per shelf
- Tempered glass on all 4 sides
- Triple glazed front with heated filaments to stop condensation
- 360° unobstructed panoramic display
- LED lighting over each level
- Self evaporating drainage
- Digital temp. control & read-out
- Rear sliding glass doors
- Fan-forced thermal air-flow & humidity
- Castors with lock down bolt for easy positioning and levelling

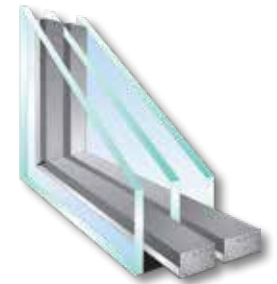

Triple Layer

Code	GEMS Star Rating	Dimensions (WxDxH mm)	Weight (kg)	Temperature Range °C	Ambient/ RH%	Voltage	Power (W/A)
Chilled Displays							
SL820V	–	600x740x1350	182	+2 to +8	40/40	240	628/10
SL830V	5	900x740x1350	184	+2 to +8	40/40	240	544/10
SL840V	4	1200x740x1350	220	+2 to +8	40/40	240	664/10
SL850V	4	1500x740x1350	257	+2 to +8	40/40	240	817/10
SL860V	4	1800x740x1350	287	+2 to +8	40/40	240	1023/10
SL880V	3	2400x740x1350	361	+2 to +8	40/40	240	1520/10
Heated Displays							
H-SL820V	–	600x740x1350	135	+30 to +85	40/40	240	986/10
H-SL830V	–	900x740x1350	170	+30 to +85	40/40	240	1126/10
H-SL840V	–	1200x740x1350	198	+30 to +85	40/40	240	1248/10

H-SL820V

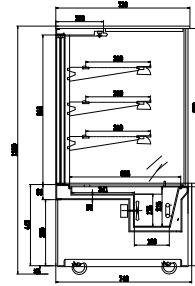
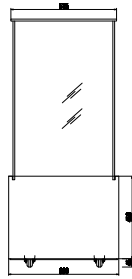

SL830V/H-SL830V

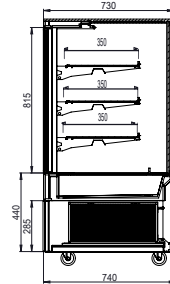
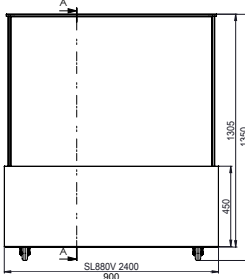

SL840V/H-SL840V

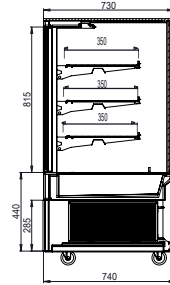
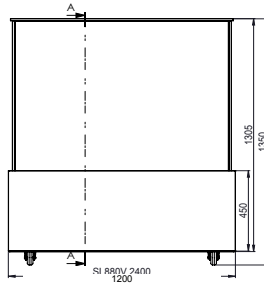

SL850V

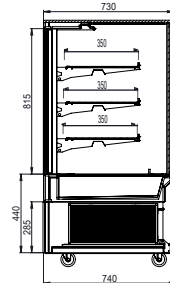
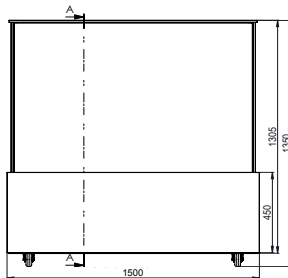

SL860V

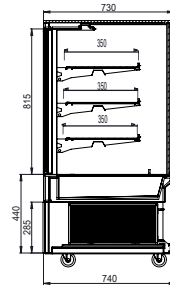
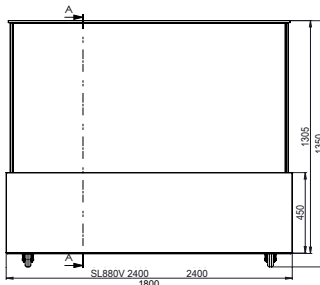

SL880V

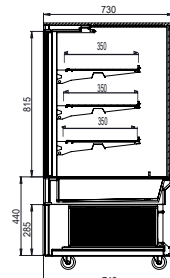
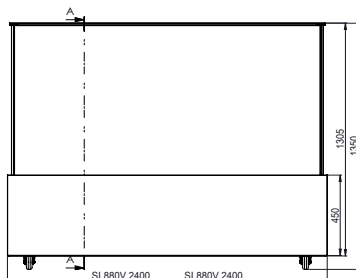

2400

Allow 100mm clearance for installation, all vents must be left clear.

Prices and specifications are subject to change without notice. Pictures are for illustrative purpose and final product may differ

Angled Dry And Wet Bain Marie / Hot Food Bar

- **Versatile Pan Compatibility:** Accommodates 1/1GN or double row ½ GN pans, up to 100mm depth, maintaining food at the ideal serving temperature (pans not included)
- **Dual Operation Modes:** Can function as both dry and wet bain marie
- **304 Stainless Steel Construction:** Durable and streamlined for easy maintenance
- **1/1 Pan Dividers Included:** With optional dividers available
- **Halogen Lighting:** With stainless steel cover and separate switch to enhance food presentation
- **Convenient Draining:** Equipped with a safety lock ball valve drain at the back
- **Analogue Temperature Display and Control:** Provides simple, manual temperature setting
- **Secure Sliding Door:** Rear tempered 5mm glass door ensures product safety and hygiene
- **Frameless Glass Design:** 8mm tempered glass frameless structure design with even heating, suitable for both wet and dry food applications
- **GN Pans and Optional Trolley are available**



BM11TC

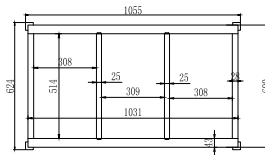
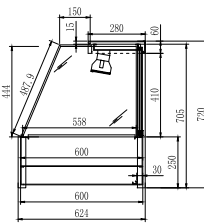
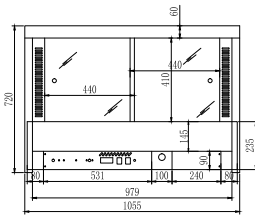

BM14TC

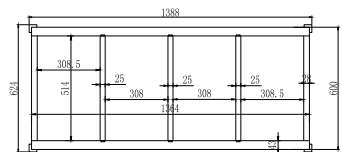
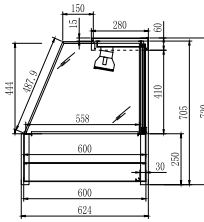
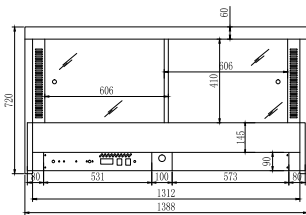

BM17TC

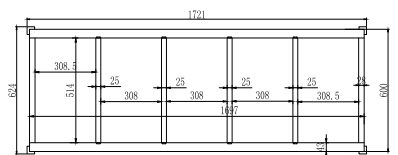
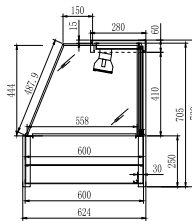
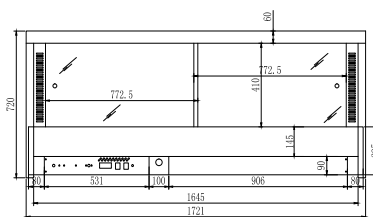

Code	Capacity (L)	Dimensions (WxDxH mm)	Weight (kg)	Temperature Range °C	Voltage	Power (W/A)
Angled Front						
BM11TC	3x 1/1GN	1055x624x720	53	35 to 85	240	2194/10
BM14TC	4x 1/1GN	1388x624x720	67	35 to 85	240	3000/15
BM17TC	5x 1/1GN	1721x624x720	81	35 to 85	240	3301/15

Trolleys

BMT11	--	1060x630x750
BMT14	--	1400x630x750
BMT17		1750x630x750



Premium S/S Cold Salad & Noodle Bar



- Constructed from all stainless steel for durability and hygiene
- Streamlined design simplifies cleaning
- Auto defrost with digital controller
- Incorporates "Blown well" cross-flow fan for efficient cooling
- Includes a 220mm deep PE chopping board
- Automatic condensation evaporation system
- Hinged cabinet doors for easy access
- Fridge has one level of shelving plus floor
- Mounted on castors for easy mobility
- Fits GN pans up to 150mm deep
- Tempered glass canopy enhances visibility and safety
- Clear sliding doors on the serving area for convenient access
- LED lighting inside illuminates contents
- 1/1 pan dividers included
- Optional GN pans available



PG150FA-XG

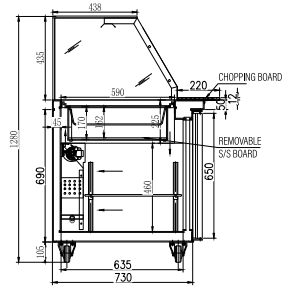
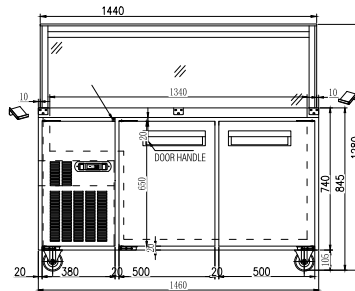

PG180FA-XG

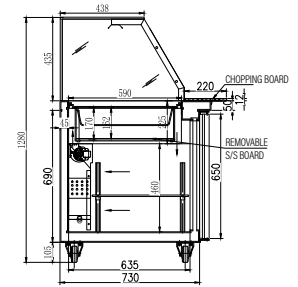
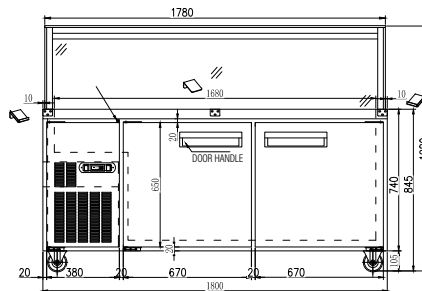

PG210FA-XG

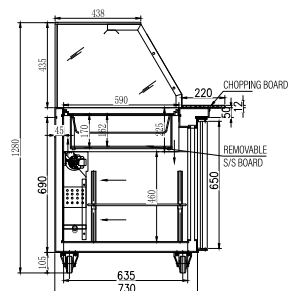
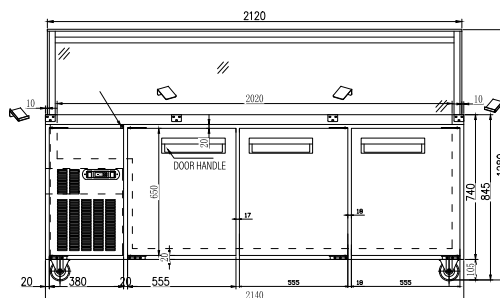

Code	Litre	Dimensions (WxDxH mm)	Weight (kg)	Temperature Range °C	Ambient/ RH%	Voltage	Power (W/A)
2 Door - 4x1/1 pans							
PG150FA-XG	600	1460x790x1280	164	+1 to +5	38/50	240	580/10
2 Door - 5x1/1 pans							
PG180FA-XG	800	1800x790x1280	179	+1 to +5	38/50	240	645/10
2 Door - 6x1/1 pans							
PG210FA-XG	1000	2140x790x1280	200	+1 to +5	38/50	240	662/10

Promotion Display Cooler / Berry Fridge



- Automatic defrost ensures efficient operation
- Easy-to-use digital controller interface
- Embraco compressor for long-lasting performance
- R290 Natural Refrigerant
- Copper finned evaporator & condenser
- Fan cooling provides even temperature distribution
- Bumper bars on 4 sides to protect the machine
- Hot gas pipe for auto condensate water
- Double tempered glass
- Good insulation effect and reduces energy consumption.
- Adjustable legs to stabilize the machine
- Two energy-efficient LED lights for clear product display
- Larger glass on 4 sides for enhanced product visibility from multiple angles
- Model PDK-1360D comes equipped with a glass door, offering both energy savings and better in maintaining temperature



PDK-1360



PDK-1360D

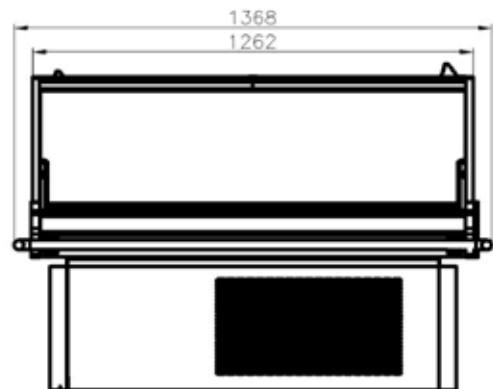
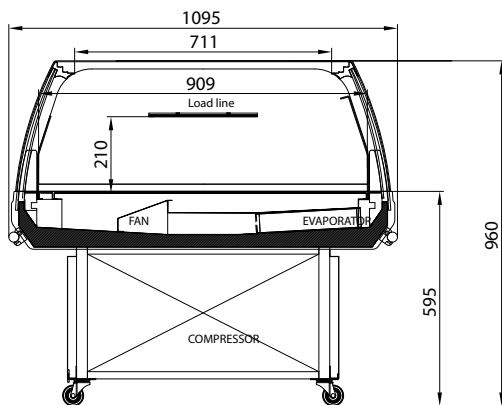

Code	Door	Dimensions (WxDxHmm)	Weight (kg)	Temperature Range °C	Ambient/ RH%	Voltage	Power (W/A)
PDK-1360	0	1360x1095x930	138	+1 to +10	25/60	240	240/10
PDK-1360D	2	1360x1095x930	148	+1 to +7	25/60	240	240/10

Premium Glass Door Multideck Display Fridge



The DC-B Range offers high-visibility refrigerated storage for packaged goods, beverages, and fresh products – perfect for convenience stores, petrol stations, compact supermarkets, grocery stores, and liquor stores. Panoramic glass sides and doors maximise product display while maintaining consistent, food-safe temperatures across multiple shelf levels.

Designed for modern commercial refrigeration, the unit features a double-glazed, tempered Low-E glass self-closing door for outstanding thermal performance, safety, and user comfort – all in a sleek, contemporary design.

- Energy saving design
- LED lighting on the top and integrated lighting on each shelf
- Adjustable shelf angle: 0° / 7° / 14°
- Self-closing doors
- Low-E glass
- Smaller base design to reduce floor footprint
- Contents are displayed from the front and two sides
- Fan force cooling
- Digital temperature display
- EC fans and Anti-reflex glass door minimize energy consumption
- Pull-out condensing unit to achieve the easiest after-sales operation
- Designed for multiplexing with building joining kits included
- Bright, Clean and Anti-glare
- Natural, eco-friendly refrigerant
- Suitable for dairy and milk drinks, packed meat, vegetables, fruits and hamburgers



DC-125B



DC-187B

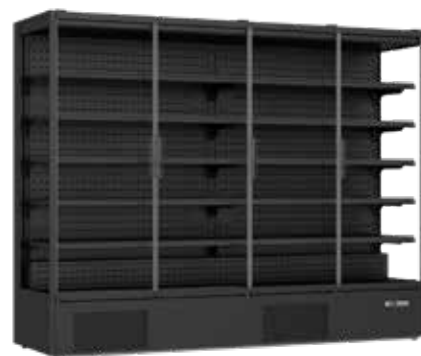

DC-250B

Code	Gross Capacity (L)	GEMS Star Rating	Display area (m ²)	Dimensions (WxDxHmm)	Weight (kg)	Temp Range °C	Ambient/ RH%	Voltage	Power (W/A)
DC-125B	1292	8	3.14	1250x60x740x2060	260	-1 to +5	25/60	240	550/10
DC-187B	1939	8	4.13	1870x60x740x2060	370	-1 to +5	25/60	240	980/10
DC-250B	2585	8	5.13	2500x60x740x2060	440	-1 to +5	25/60	240	1060/10

Supermarket Open Beverage Display



The OC Range open multideck beverage display unit offers high-visibility chilled storage, ideal for supermarkets, convenience stores, and cafés. Featuring energy-efficient refrigeration, bright LED lighting, and adjustable shelving, it maximises product presentation while maintaining consistent temperatures. Its open-front design ensures easy customer access and quick restocking, and studies show that open displays can increase beverage sales by up to 15%

- Smaller base design to reduce floor footprint
- Double layer night blinds for less energy consumption
- Fan force cooling with air curtain
- Illuminated top canopy for advertising
- Streamlined operation
- Adjustable Shelf Angle: 0° / 7° / 14°
- Temperature Class: M2 ideal for most refrigerated drinks
- LED lighting on the top and integrated lighting on each shelf
- Natural, eco-friendly refrigerant

OC-915B

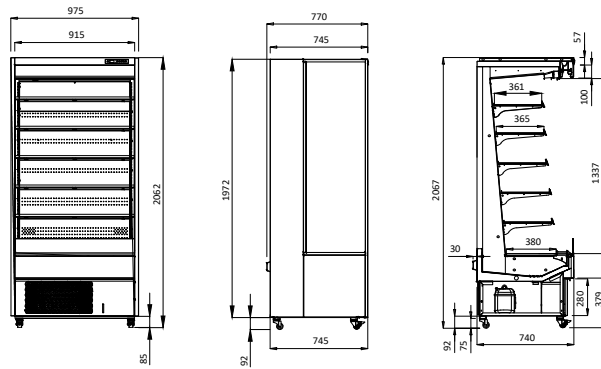

OC-1220B

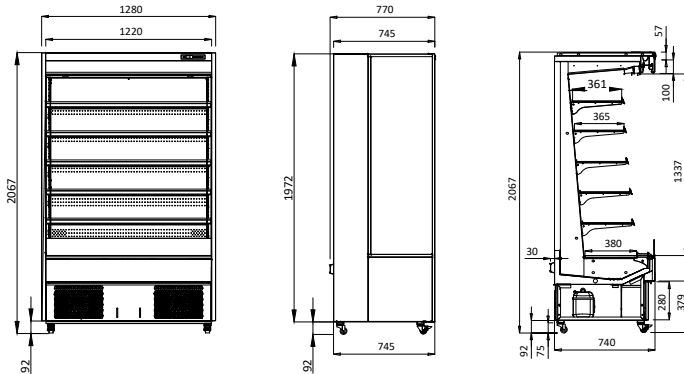

OC-1830B

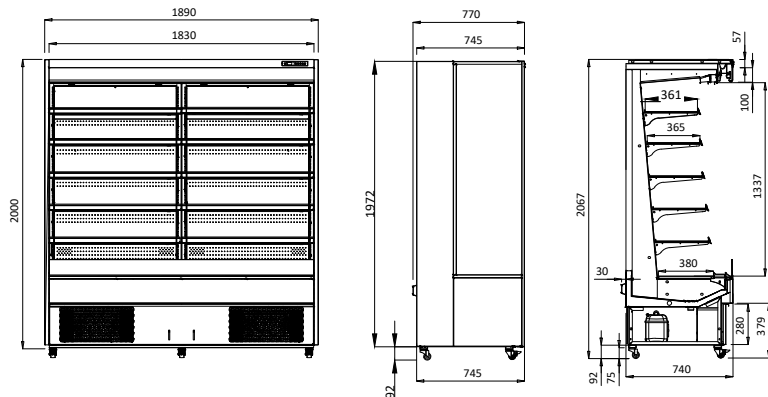

Code	Litre	Night Blinds	Display area (m ²)	Dimensions (WxDxHmm)	Weight (kg)	Temperature Range °C	Ambient/ RH%	Voltage	Power (W/A)
OC-915B	405	2	1.92	975x770x2067	216	+1 to +7	25/60	240	910/10
OC-1220B	540	2	2.32	1280x770x2067	275	+1 to +7	25/60	240	1390/15
OC-1830B	810	2	3.11	1890x770x2067	330	+1 to +7	25/60	240	1800/15

Supermarket Open Beverage Display



The OC Range open multideck beverage display unit offers high-visibility chilled storage, ideal for supermarkets, convenience stores, and cafés. Featuring energy-efficient refrigeration, bright LED lighting, and adjustable shelving, it maximises product presentation while maintaining consistent temperatures. Its open-front design ensures easy customer access and quick restocking, and studies show that open displays can increase beverage sales by up to 15%

- Smaller base design to reduce floor footprint
- Double layer night blinds for less energy consumption
- Fan force cooling with air curtain
- Illuminated top canopy for advertising
- Streamlined operation
- Adjustable Shelf Angle: 0° / 7° / 14°
- Temperature Class: M2 ideal for most refrigerated drinks
- LED lighting on the top and integrated lighting on each shelf
- Natural, eco-friendly refrigerant

OC-915

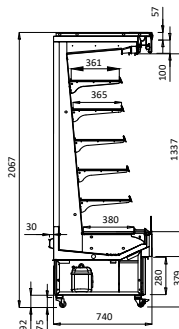
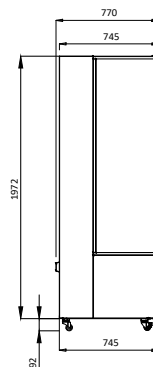
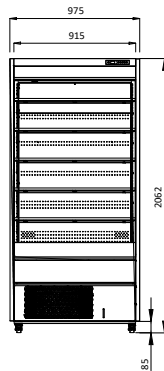

OC-1220

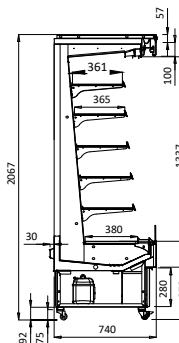
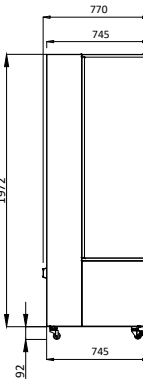
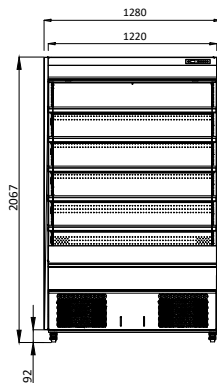

OC-1830

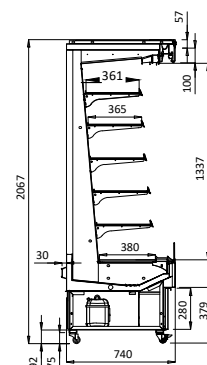
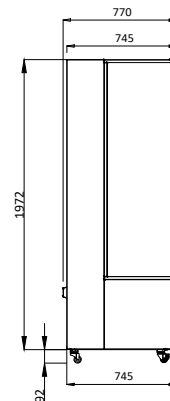
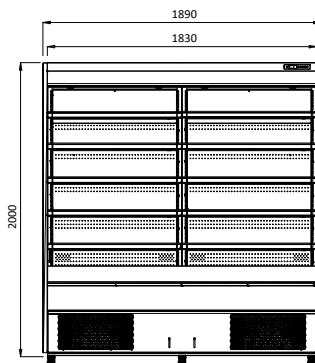

Code	Litre	Night Blinds	Display area (m ²)	Dimensions (WxDxHmm)	Weight (kg)	Temperature Range °C	Ambient/ RH%	Voltage	Power (W/A)
OC-915	405	2	1.92	975x770x2067	216	+1 to +7	25/60	240	910/10
OC-1220	540	2	2.32	1280x770x2067	275	+1 to +7	25/60	240	1390/15
OC-1830	810	2	3.11	1890x770x2067	330	+1 to +7	25/60	240	1800/15

Open Top Beverage Display Fridge/Cooler



- Great to put under or near cash register – maximises point-of-sale impulse purchases and makes it easy for staff to restock without leaving the counter
- Dynamic fan-forced cooling system – ensures consistent, even cooling throughout the cabinet, keeping beverages perfectly chilled at all times
- Natural and eco-friendly refrigerant – reduces environmental impact while delivering reliable refrigeration performance
- With LED display for inside temperature & defrost timer – allows quick, accurate monitoring and simple control over operation
- Full LED illumination for attraction and display – enhances product visibility, drawing customer attention to chilled drinks.
- User-friendly self-evaporation stainless steel water tray – eliminates manual water disposal and resists corrosion for long-term hygiene.
- 4 wheels and fixed position bolts – easy to move for cleaning or rearranging, then lock securely in place for stability.
- Easy-maintenance condenser dust-proof mesh for easy cleaning – helps maintain performance and prolongs equipment life.
- Open-top design – provides quick grab-and-go access to products, improving service speed and customer convenience.
- Compact footprint – ideal for maximising sales in smaller retail or hospitality spaces
- Energy-efficient design – helps lower power consumption and reduce running costs.

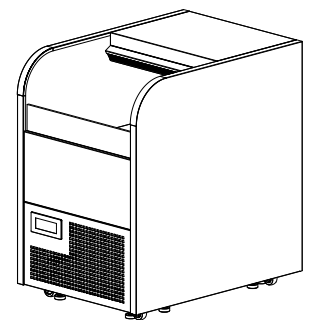
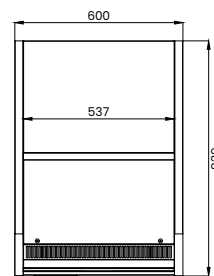
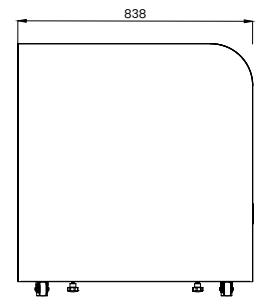
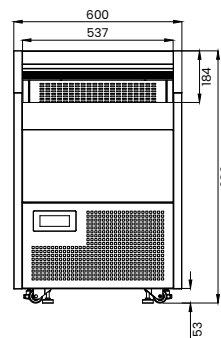

Code	Capacity (L)	Dimensions (WxDxH mm)	Weight (kg)	Temperature Range °C	Voltage	Power (W/A)
WN-DC120	120	600x838x900	81	+2 to +8	240	536/10

Grab & Go Hot Or Cold Cabinet



Perfect for cafes, convenience stores, and workplaces, this grab-and-go cabinet blends functionality, efficiency, and style to elevate your food service offering.

- Embraco Compressor ensures robust, consistent cooling/heating performance for reliable 24/7 operation. (Excluding the hot cabinet)
- Intelligent temperature control with a precision-driven smart thermostat
- 360° surround air-cooling, equipped with a high-efficiency air circulation system that distributes temperatures evenly across all shelves, eliminating hot/cold spots
- Copper-aluminium evaporator with aluminium fins for superior heat transfer
- Auto-defrost function and hassle-free maintenance with automatic defrosting, reducing manual upkeep and ensuring uninterrupted performance
- Engineered for energy savings without compromising performance, aligning with AU/NZ energy efficiency standards to lower operational costs
- Constructed with electro-galvanized steel, food-grade stainless steel, and a sleek matte black finish, combining corrosion resistance with modern aesthetics
- Double-Pane Side Glass – high-transparency, insulated double-glazed panels enhance product visibility while minimising heat loss, keeping contents at ideal temperatures
- Four adjustable shelves provide ample capacity for a variety of snacks, beverages, or meals, maximising display flexibility for busy retail environments

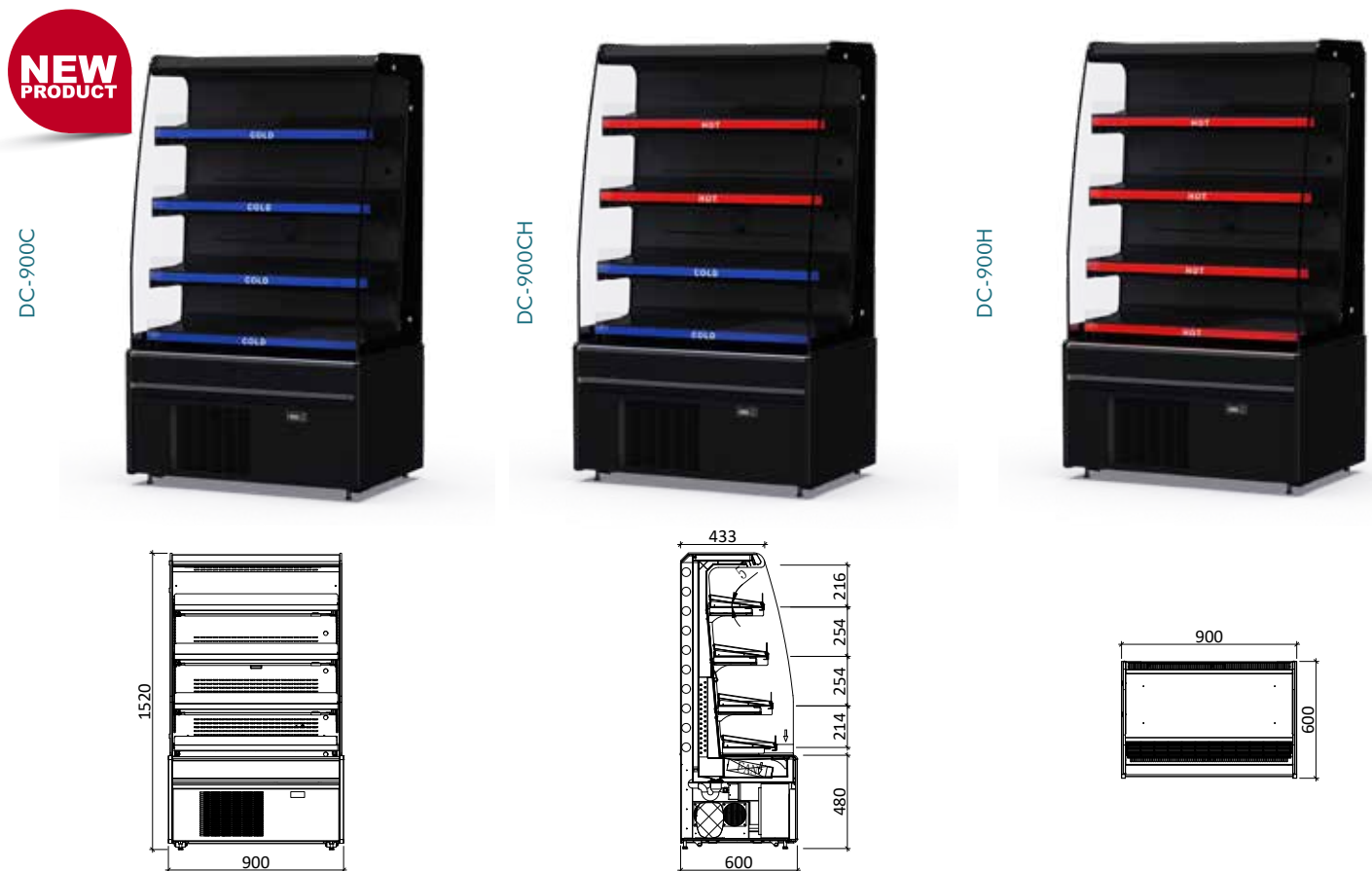

Code	GEMS Star Rating	Gross Capacity (L)	Net Capacity (L)	Dimensions (WxDxH mm)	Weight (kg)	Temperature Range °C	Voltage	Power (kW/A)
DC-900C	4	253	202	900x600x1520	131	+3 to +8	240	1.16/10
DC-900CH	4	253	202	900x600x1520	141	+3 to +8 / +50 to +60	240	1.5/10
DC-900H	-	253	202	900x600x1520	103	+50 to +60	240	1.0/10

Grab & Go Evo Self-Serve Display

- Ideal for placement in narrow spaces
- Efficient and reliable refrigeration system
- Easy installation
- Low energy consumption and low environmental impact
- Tempered side glass with double glazing and air deflector glass
- Perforated back and interior ceiling for improved air circulation
- Removable lower display shelves
- 3 Stainless steel adjustable shelves
- LED lighting on the ceiling and each of the 3 shelves
- Electronic control panel
- Off-cycle defrosting
- Suitable for displaying gastronomy items, packaged snacks and pastries, beverages, cold cuts, and dairy products
- Four lockable castors

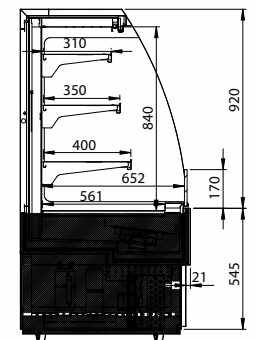

SEZIONE C-C

Tutti i diritti sono riservati. L'utilizzo è consentito a terzi previa autorizzazione della Tecnomat.

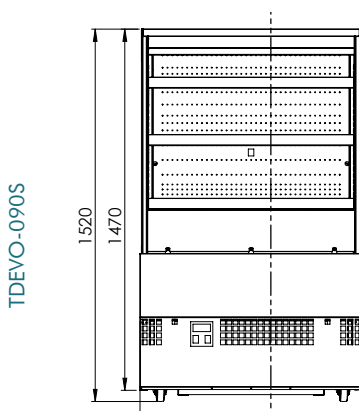

TDEVO-090S

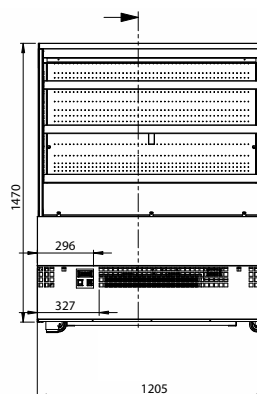

TDEVO-120S

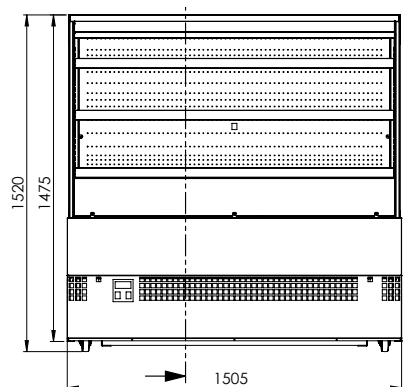

TDEVO-150S

Code	Display Surface (m ²)	Dimensions (WxDxH mm)	Weight (kg)	Temperature Range °C	Ambient/ RH%	Voltage	Power (kW/A)
TDEVO-090S	1.41	905x800x1520	165	+3 to +5	30/55	240	1.266/10
TDEVO-120S	1.94	1205x800x1520	195	+3 to +5	30/55	240	1.15/10
TDEVO-150S	2.43	1505x800x1520	239	+3 to +5	30/55	240	1.496/10

Grab & Go Evo Self-Serve Display



- Innovative refrigeration system with air curtain
- Elegant design suitable for any concept design
- 1,75 m² Display surface
- Top, side and rear external tempered double-glazed glass
- Tempered glass deflectors
- 3 adjustable tempered glass shelves, 350mm depth
- Plexiglass rear internal profile for the best visibility of the products (granting a fast supply)
- Drilled internal top and back side for a better air circulation
- 2 vertical LED lighting installed on both sides
- Electronic control panel
- High-density CFC-free polyurethane insulation
- Easily accessible condensing unit and compressor at the bottom
- Ventilated refrigeration system
- Removable bottom trays
- Automatic water evaporation system
- Timed defrosting
- Suitable for displaying: Gastronomy, packaged snack and pastry, beverage and snack
- Interior and exterior in black

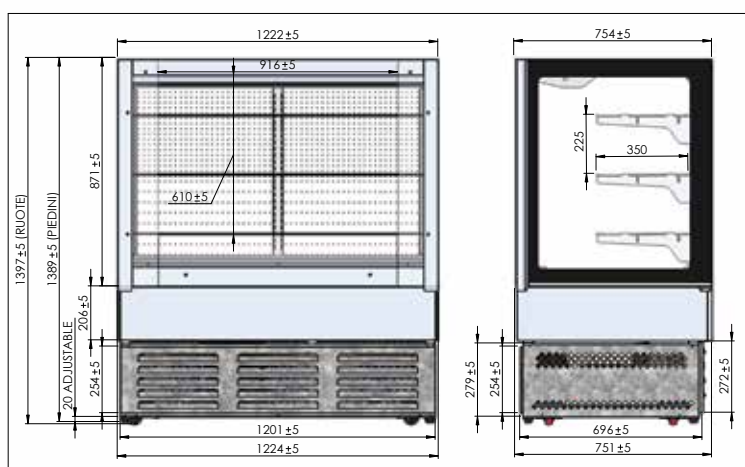

Code	Dimensions (WxDxH mm)	Weight (kg)	Temperature Range °C	Ambient/ RH%	Voltage	Power (W/A)
TDEVO-120V	1224x754x1389	195	+3 to +5	30/55	240	880/10

Vulcano Supermarket Display

- Ventilated cooling system for even temperature across all shelves
- Built-in condensing unit with automatic water evaporation system
- Stainless steel serpentine (CG) for efficient cooling performance
- Climate Class 4 rated for 30°C ambient with 60% RH
- Easy installation with low maintenance requirements
- Mounted on castors for flexible supermarket positioning
- Ideal for beverages, dairy and grab-and-go displays



TDVC60-CA-100

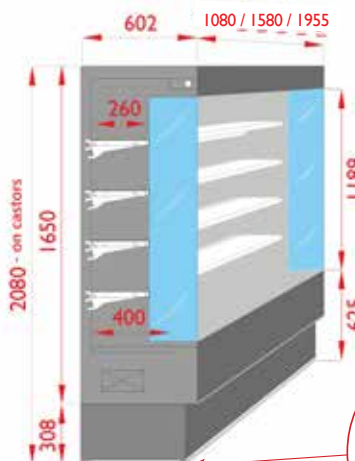

TDVC80-CA-150

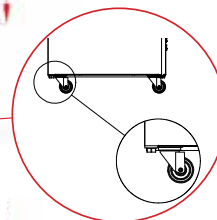
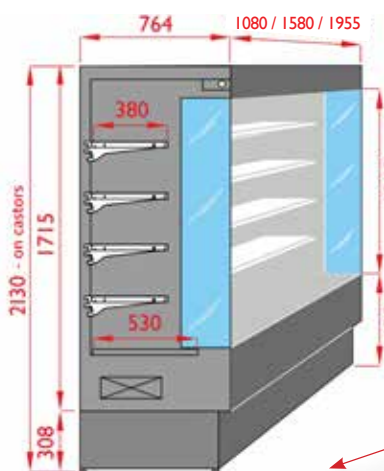

Code	Dimensions (WxDxH mm)	Weight (kg)	Temperature Range °C	Ambient/ RH%	Voltage	Power (W/A)
602mm Deep						
TDVC60-CA-100	1080x602x2080	140	0 to +2	30/60	240	1220/10
TDVC60-CA-125	1330x602x1970	170	0 to +2	30/60	240	1370/10
TDVC60-CA-150	1580x602x2080	225	0 to +2	30/60	240	1520/15
TDVC60-CA-187	1955x602x2080	255	0 to +2	30/60	240	1850/20
764mm Deep						
TDVC80-CA-100	1080x764x2135	180	0 to +2	30/60	240	2275/10
TDVC80-CA-150	1580x764x2135	240	0 to +2	30/60	240	2721/15
TDVC80-CA-187	1955x764x2135	280	0 to +2	30/60	240	4070/15+10

Vulcano Supermarket Display

- Easy to install and lower maintenance cost
- Fitted with Automatic water Evaporation system with Stainless Steel Serpentine (CG)
- 2 plugs (one extra, separate circuit for the tropical tundish), as requested, that runs with a separate element of 1000W, hence the extra 10Amp you find in each model
- Ventilated Cooling System
- Climate Class 4, Ambient of 30°C with 55% RH
- Castors
- Built-in condensing unit



TDVB80-CA-125

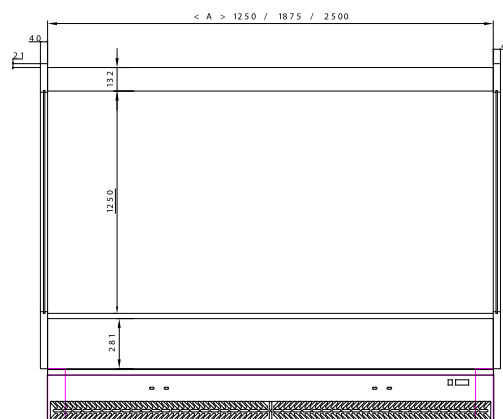
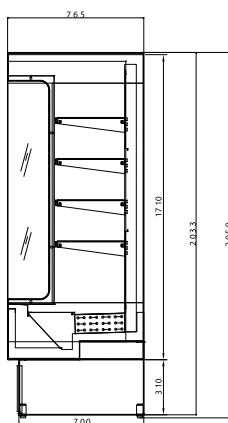

TDVB80-CA-250



Code	Dimensions (WxDxH mm)	Weight (kg)	Temperature Range °C	Ambient/ RH%	Voltage	Power (W/A)
TDVB80-CA-125	1330x900x2130	210	0 to +4	30/55	240	1830W + 1000W (2 x 10Amp)
TDVB80-CA-187	1955x900x2130	280	0 to +4	30/55	240	3100W + 1000W (1 x 15Amp + 1 x 10Amp)
TDVB80-CA-250	2580x900x2130	400	0 to +4	30/55	240	4330W + 1000W (1 x 20Amp + 1 x 10Amp)

Stromboli Multideck Display with Doors

- Hinged door
- Compact but with a large display area
- Suitable for large retail outlets
- Italian technology, design and production
- Easy installation
- Four legs
- Optimised cleaning system
- Low energy consumption and low environmental impact
- Belly made without the use of CFC
- Type of defrost: Electric with heating element
- Fan Forced
- Tempered double glazing glass (thickness 30 mm)
- 434mm deep shelf
- 279mm gap between each shelf
- Electronic control panel
- LED lights at ceiling top and each shelf
- Transparent glass side wall to max the product display

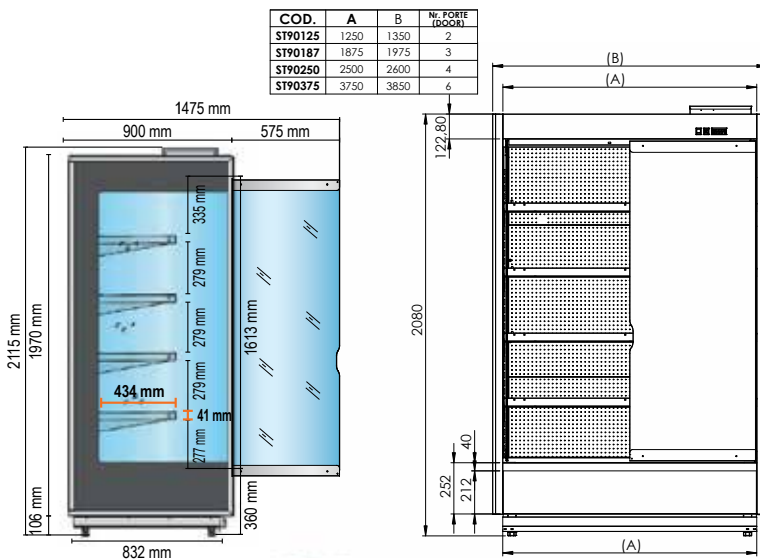
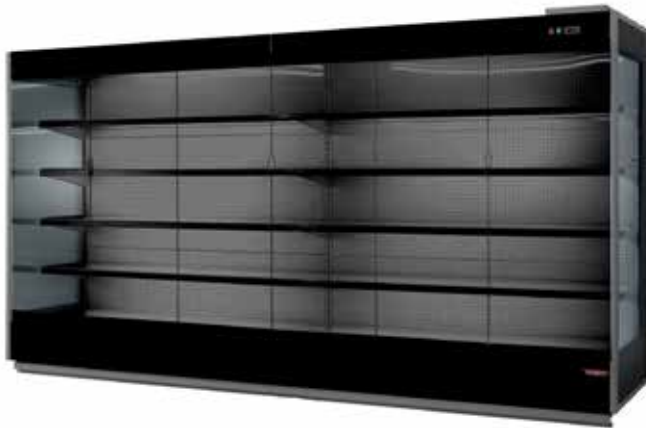

Code	Net Volume (m3)	Door	Display area (m ²)	Dimensions (WxDxH mm)	Weight (kg)	Temperature Range °C	Ambient/ RH%	Voltage	Power (kW/A)
TDST90-CA-125BD	2.387	2	2.92	1350x900x2115	200	0 to +2	30/55	240	0.75/10
TDST90-CA-187BD	3.58	3	4.34	1975x900x2115	300	0 to +2	30/55	240	1.12/10
TDST90-CA-250BD	4.774	4	5.84	2600x900x2115	400	0 to +2	30/55	240	1.5/10
TDST90-CA-375BD	7.161	6	8.68	3850x900x2115	600	0 to +2	30/55	240	2.25/10

Stromboli Multideck Open Display

- Night blinds
- Compact but with a large display area
- Suitable for large retail outlets
- Italian technology, design and production
- Easy installation
- Four legs
- Optimised cleaning system
- Low energy consumption and low environmental impact
- Belly made without the use of CFC
- Type of defrost: Electric with heating element
- Fan Forced
- Tempered double glazing glass (thickness 30 mm)
- 434mm deep shelf
- 279mm gap between each shelf
- Electronic control panel
- LED lights at ceiling top and each shelf
- Transparent glass side wall to max the product display

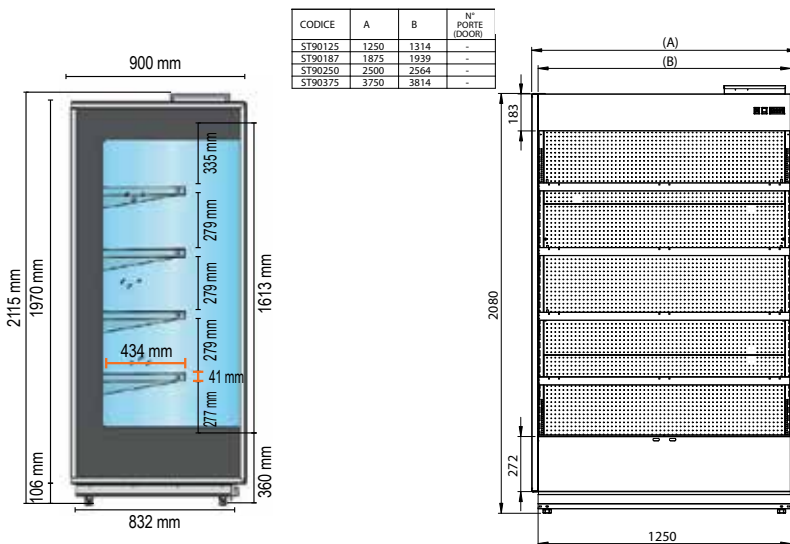

Code	Net Volume (m3)	Display area (m ²)	Dimensions (WxDxH mm)	Weight (kg)	Temperature Range °C	Ambient/ RH%	Voltage	Power (kW/A)
TDST90-CA-125B	2.387	2.92	1314x900x2115	200	0 to +2	30/55	240	0.75/10
TDST90-CA-187B	3.58	4.34	1939x900x2115	300	0 to +2	30/55	240	1.12/10
TDST90-CA-250B	4.774	5.84	2564x900x2115	400	0 to +2	30/55	240	1.5/10
TDST90-CA-375B	7.161	8.68	3814x900x2115	600	0 to +2	30/55	240	2.25/10

Benchtop Glass Door Beverage Fridge



- LED lighting to enhance product visibility
- Double glazed glass door for efficient insulation
- Fan-forced cooling for even temperature

- Digital temperature control with display
- Adjustable shelves for flexible storage
- Automatic defrost for easy maintenance

- Self-evaporating drainage system
- CFC and HCFC free insulation
- Ambient rated up to 32°C



AMBIENT 32°C

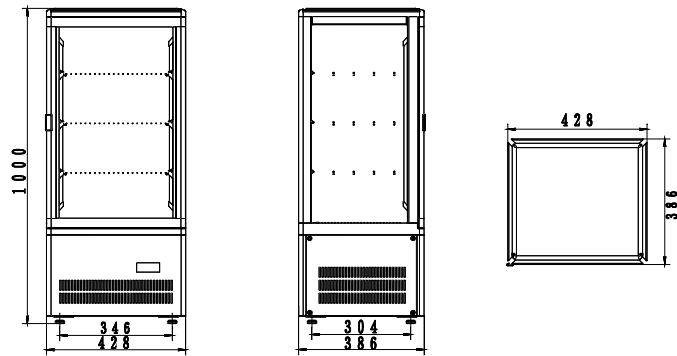

Code	GEMS Star Rating	Gross Capacity (L)	Net Capacity (L)	Dimensions (WxDxH mm)	Weight (kg)	Temperature Range °C	Ambient/ RH%	Voltage	Power (W/A)
TCBD78W (White)	7	78	63	428x386x1000	39	+2 to +8	32/60	240	160/10
TCBD78B (Black)	7	78	63	428x386x1000	39	+2 to +8	32/60	240	160/10

Benchtop Glass Door Beverage Fridge

- LED lighting for strong product visibility
- Double glazed glass for efficient insulation
- Fan-forced cooling for even temperature

- Digital temperature control
- Adjustable shelves for flexible storage
- Automatic defrost system

- Self-evaporating drainage
- CFC and HCFC free insulation
- 10 star energy rating



TCBD108L

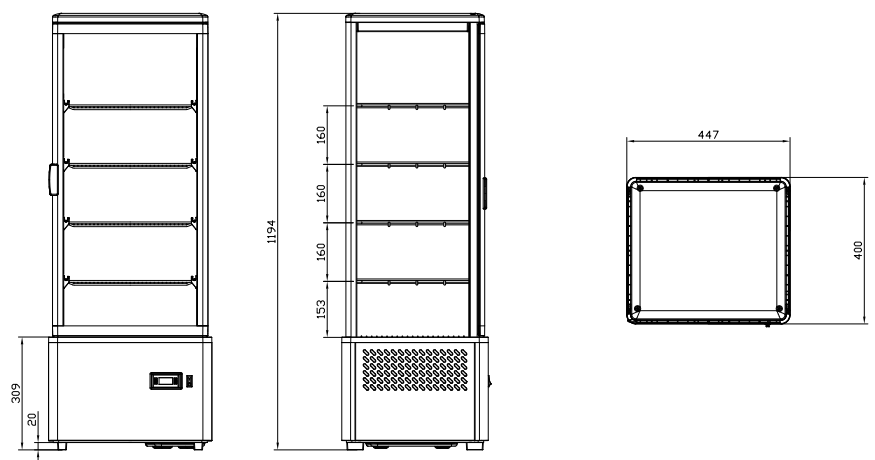

Code	Litres	Dimensions (WxDxH mm)	Weight (kg)	Temperature Range °C	Ambient/ RH%	Voltage	Power (W/A)
TCBD108L	108	447x400x1194	43.5	0 to +12	30/55	240	260/10

Upright Glass Door Beverage Fridge



- LED lighting
- Double glazed
- Fan-forced evaporator cooling

- Digital temp. controls & read-out
- Adjustable shelves
- Auto defrost

- Self evaporating drainage
- Insulation is CFC & HCFC free



AMBIENT 32°C

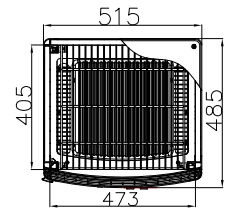
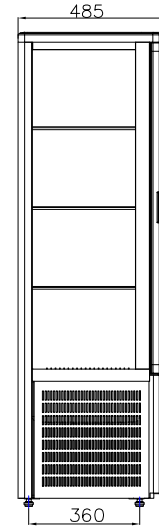
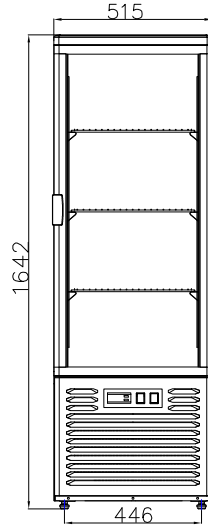

Code	GEMS Star Rating	Gross Capacity (L)	Net Capacity (L)	Dimensions (WxDxH mm)	Weight (kg)	Temperature Range °C	Ambient/ RH%	Voltage	Power (W/A)
LSC235	7	220	168	515x485x1618	70	+2 to +8	32/60	240	260/10

SlimFit Upright Glass Door Beverage Fridge

- Digital display and controller
- Dual lighting system with independent light switch
- Recessed handle design
- Aluminium alloy curved door frame
- Adjustable shelving – Flexible configuration options
- Lockable design
- Fan-forced cooling system with auto-defrosting and self-evaporation
- Dust-resistant protection for easier compressor maintenance
- Door is not reversible, left hinge opening available on request

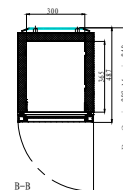
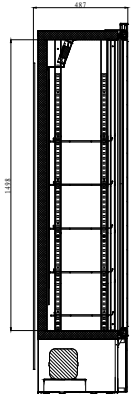
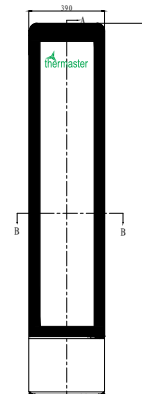

Code	Gross Capacity (L)	Net Capacity (L)	Dimensions (WxDxH mm)	Weight (kg)	Temperature Range °C	Ambient/ RH%	Voltage	Power (W/A)
LG166FA	166	144	390x487x1918	58	0 to +10	32/60	240	200/10

HIPS Beverage Fridge



The Upright Glass Door HIPS Beverage Fridge integrates a variety of high-quality features. Its exterior, made of black painted steel, is stylish, attractive, and durable. The LED lighting design is energy-efficient, providing a clear and bright interior view. The efficient cooling system ensures long-lasting and stable cooling performance and excellent energy efficiency.

The device features a frost-free design and a self-evaporation system, making it more convenient and worry-free to use. Combining practical and user-friendly operation functions with safe and efficient performance ensures outstanding performance in commercial environments.

- Durable HIPS Interior Liner resists cracking and chipping from daily commercial use
- Hygienic HIPS Surface easy to clean, odour-resistant, and food-safe
- Lightweight construction contributes to lower unit weight and easier handling
- Digital control and temperature display
- Double glazed, external tempered glass
- Fan-forced cooling
- Frost free design
- Natural and eco-friendly refrigerant
- Slimmer size without compromising on loading quantity
- Auto evaporation
- 10 Star GEMS Rating
- Condensation barrier
- 2 Casters & 2 Feet
- 20kg shelf capacity
- Bright, clean and anti-glare embedded LED ceiling light
- Door is not reversible, left hinge opening available on request



Code	GEMS Star Rating	Gross Capacity (L)	Net Capacity (L)	Dimensions (WxDxH mm)	Weight (kg)	Temp. Range °C	Ambient/ RH%	Voltage	Power (W/A)
SDC-178B	10	200	178	540x560x1325	39	+2 to +7	35/75	240	180/10
SDC-258B	10	280	258	540x560x1725	47	+2 to +7	35/75	240	240/10
SDC-343B	10	380	343	595x607x1876	60	+2 to +7	35/75	240	300/10

Upright Glass Door Beverage Fridge



- Digital temperature control with clear read-out
- Forced air circulation for even cooling
- Interior LED lighting for product visibility
- Double glazed tempered glass door
- Four adjustable shelves for flexible display
- Self-closing door for energy efficiency
- Natural eco-friendly refrigerant
- Self-evaporative drainage system
- Mounted on castors, 2 with brakes



AMBIENT 38°C

LG-370P/LG-370BP

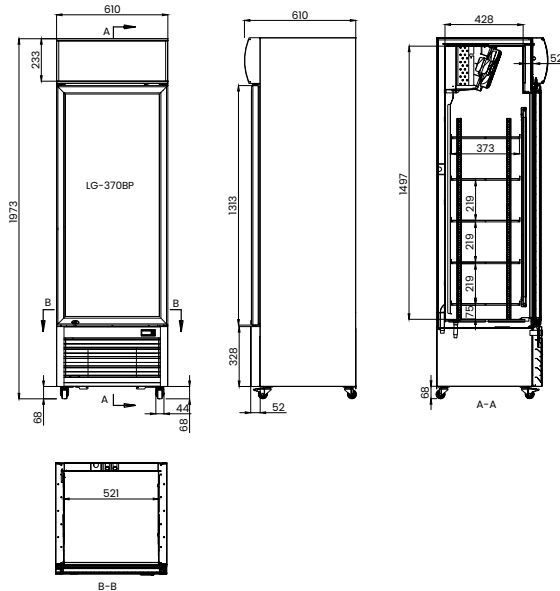

LG-540P / LG-540BP

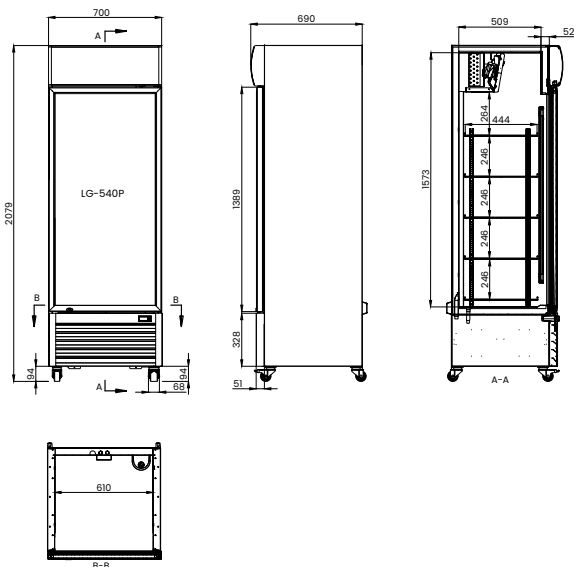

Code	GEMS Star Rating	Gross Capacity (L)	Net Capacity (L)	Dimensions (WxDxH mm)	Weight (kg)	Temperature Range °C	Ambient/ RH%	Voltage	Power (W/A)
LG-370P (White)	9	370	335	610x610x1973	72	+2 to +7	38/65	240	268/10
LG-370BP (Black)	9	370	335	610x610x1973	72	+2 to +7	38/65	240	268/10
LG-540P (White)	9	495	530	700x690x2079	83	+2 to +8	38/65	240	310/10
LG-540BP (Black)	9	495	530	700x690x2079	83	+2 to +8	38/65	240	310/10

Upright Glass Door Beverage Fridge



- Digital temperature control with clear read-out
- Forced air circulation for even cooling
- Interior LED lighting for product visibility
- Double glazed tempered glass door
- Four adjustable shelves for flexible display
- Self-closing door for energy efficiency
- Natural eco-friendly refrigerant
- Self-evaporative drainage system
- Mounted on castors, 2 with brakes



AMBIENT 38°C

LG-580P / LG-580BP

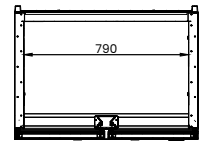
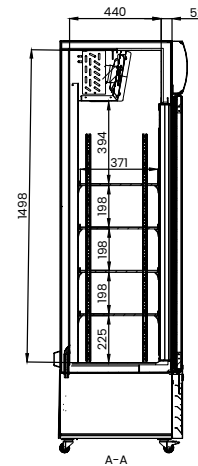
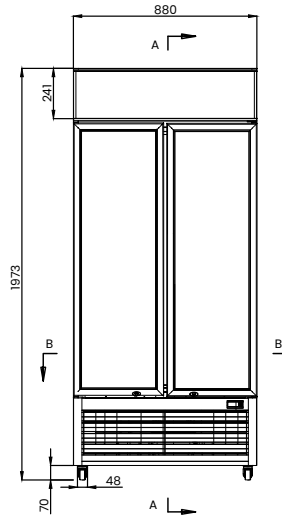

LG-730P / LG-730BP

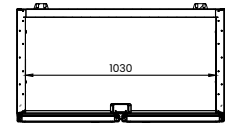
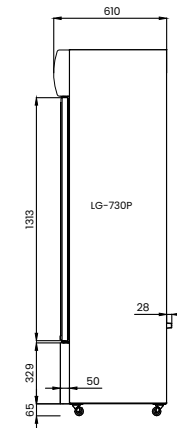
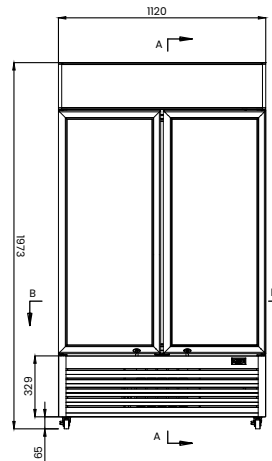

Code	GEMS Star Rating	Gross Capacity (L)	Net Capacity (L)	Dimensions (WxDxH mm)	Weight (kg)	Temp. Range °C	Ambient/ RH%	Voltage	Power (W/A)
LG-580P (White)	7	568	487	880x610x1973	96.5	+2 to +8	38/65	240	349/10
LG-580BP (Black)	7	568	487	880x610x1973	96.5	+2 to +8	38/65	240	349/10
LG-730P (White)	7	730	670	1120x610x1973	113	+2 to +8	38/65	240	450/10
LG-730BP (Black)	7	730	670	1120x610x1973	113	+2 to +8	38/65	240	450/10

Upright Glass Door Beverage Fridge



- Digital temperature control with clear read-out
- Forced air circulation for even cooling
- Interior LED lighting for product visibility
- Double glazed tempered glass door
- Four adjustable shelves for flexible display
- Self-closing door for energy efficiency
- Natural eco-friendly refrigerant
- Self-evaporative drainage system
- Mounted on castors, 2 with brakes



AMBIENT 38°C

LG-1000P / LG-1000BP



LG-1000SDBP



LG-1200P

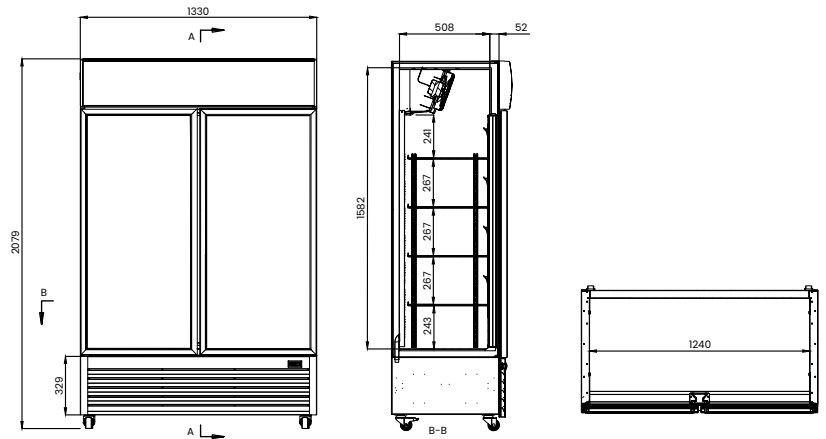
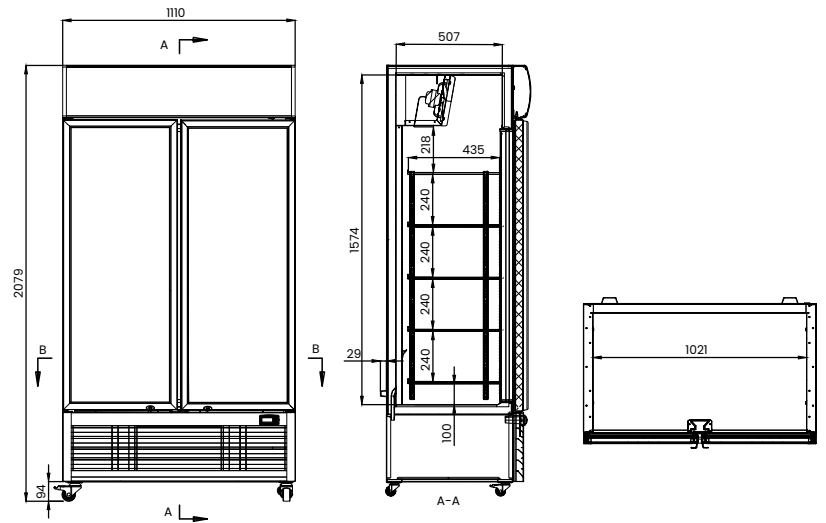

Code	GEMS Star Rating	Gross Capacity (L)	Net Capacity (L)	Dimensions (WxDxH mm)	Weight (kg)	Temp. Range °C	Ambient/ RH%	Voltage	Power (W/A)
LG-1000P (White)	8	885	825	1110x690x2079	123	+2 to +8	38/65	240	470/10
LG-1000BP (Black)	8	885	825	1110x690x2079	123	+2 to +8	38/65	240	470/10
LG-1000SDBP (Sliding door, Black)	8	862	803	1110x690x2079	126	+2 to +8	38/65	240	470/10
LG-1200P (White)	8	1075	1000	1330x690x2079	132	+2 to +8	38/65	240	480/10
LG-1200BP (Black)	8	1075	1000	1330x690x2079	132	+2 to +8	38/65	240	480/10

Upright Glass Door Freezer



- Slim glass door frame for maximum product visibility
- Triple glazed door with heat film for insulation
- Fan-forced cooling for consistent freezing
- Digital temperature display
- Auto defrost system
- Self-closing door for energy efficiency
- Interior LED lighting with lightbox
- Five shelves per door for organised display
- Natural eco-friendly refrigerant
- Mounted on castors for easy positioning



AMBIENT 25°C

LG-400PF

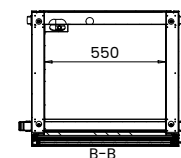
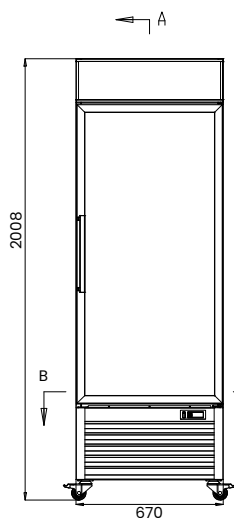

LG-800PF

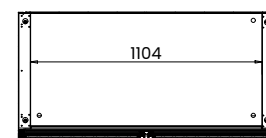
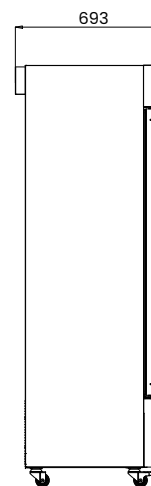
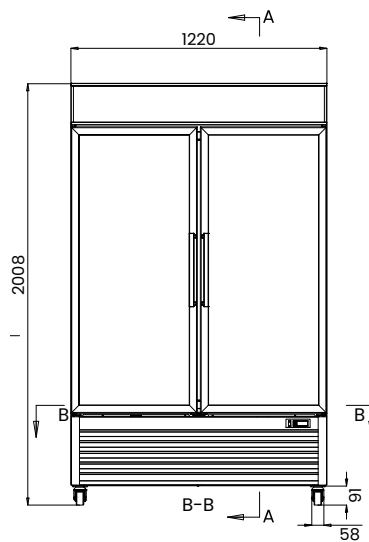

Code	GEMS Star Rating	Gross Capacity (L)	Net Capacity (L)	Dimensions (WxDxH mm)	Weight (kg)	Temp. Range °C	Ambient/ RH%	Voltage	Power (W/A)
Single door									
LG-400PF	3	400	343	670x693x2008	110	-22 to -18	25/60	240	800/10
Double door									
LG-800PF	2	800	684	1220x693x2008	189	-22 to -18	25/60	240	1500/10

Glass Door Supermarket Fridges



- Adjustable shelving for flexible product display
- Interior LED lighting to enhance visibility
- Double glazed tempered glass doors
- Self-closing doors with integrated locks
- Self-evaporating drip tray for low maintenance
- Powder coated interior for durability
- Aluminium door frame and handle
- Natural eco-friendly refrigerant
- Mounted on universal wheels for easy positioning



AMBIENT 38°C

LG-600GBM

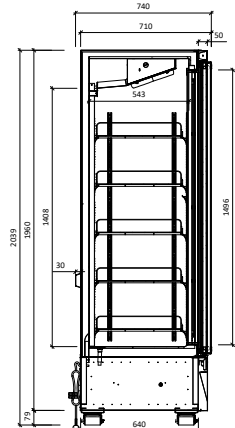
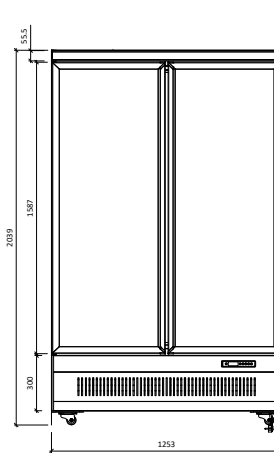
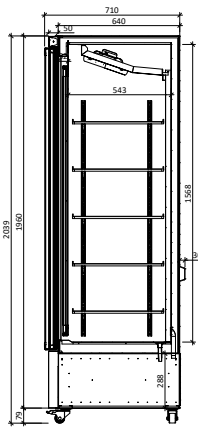
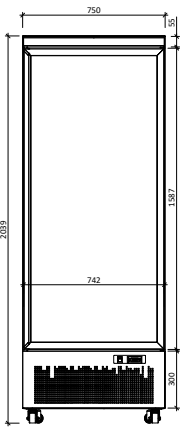

LG-1500GBM

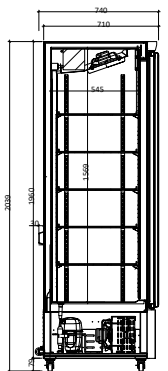
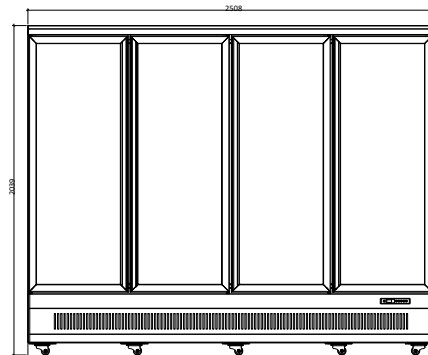
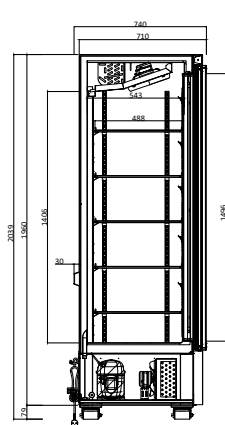
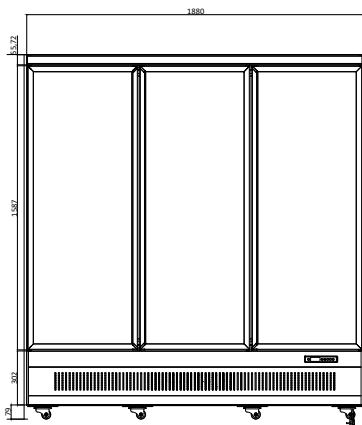

Code	Doors	GEMS Star Rating	Gross Capacity (L)	Net Capacity (L)	Dimensions (WxDxH mm)	Weight (kg)	Temp. Range °C	Ambient/ RH%	Voltage	Power (W/A)
LG-600GBM	1	8	636	579	750x740x2039	130	+2 to +8	38/65	240	460/10
LG-1000GBM	2	8	1117	1013	1253x740x2039	179	+2 to +8	38/65	240	460/10
LG-1500GBM	3	6	1718	1552	1880x740x2039	207.5	+2 to +8	38/65	240	700/10
LG-2200GBM	4	6	2319	2092	2508x740x2039	360	+2 to +8	38/65	240	920/10

Glass Door Supermarket Freezers



- Forced air circulation for consistent freezing
- Adjustable shelves for flexible storage
- Interior LED lighting for clear visibility
- Triple glazed tempered glass doors
- Self-closing doors with integrated locks
- Self-evaporating drip tray
- Powder coated interior for durability
- Aluminium door frame and handle
- Natural eco-friendly refrigerant
- Mounted on universal wheels for easy movement



LG-600GBMF/E

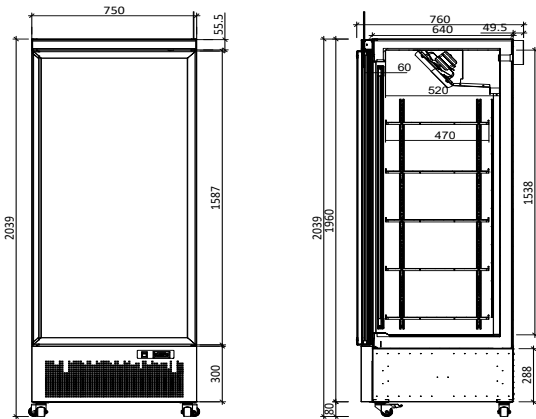

LG-1000GBMF / LG-1000GBMF/E

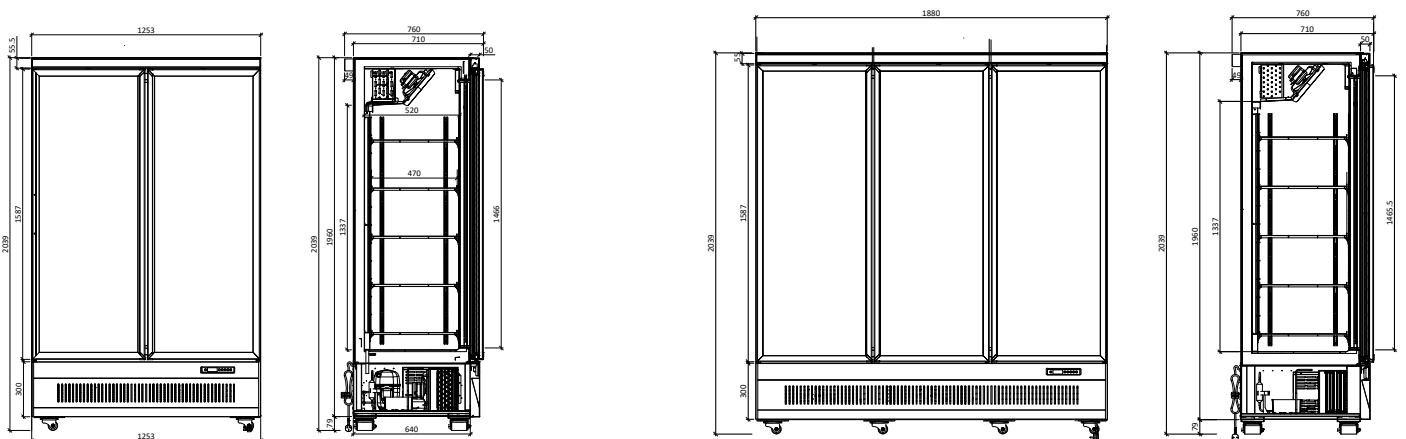

Code	Doors	GEMS Star Rating	Gross Capacity (L)	Net Capacity (L)	Dimensions (WxDxH mm)	Weight (kg)	Temp. Range °C	Ambient/ RH%	Voltage	Power (W/A)
LG-1000GBMF	2	2	1043	897	1253x760x2039	240	-22 to -18	25/60	240	1205/10
LG-1500GBMF	3	2	1618	1382	1880x760x2039	305	-22 to -18	25/60	240	1580/15
Lower Energy Consumption Range										
LG-600GBMF/E	1	4	580	390	750x740x2039	150	-22 to -18	25/60	240	600/10
LG-1000GBMF/E	2	3	1006	897	1253x760x2039	240	-22 to -18	25/60	240	1205/10
LG-1500GBMF/E	3	3	1563	1382	1880x760x2039	305	-22 to -18	25/60	240	1280/10

Glass Door Supermarket Fridges



- Adjustable shelving for flexible product display
- Interior LED lighting to enhance visibility
- Double glazed tempered glass doors
- Self-closing doors with integrated locks
- Self-evaporating drip tray for low maintenance
- Powder coated interior for durability
- Aluminium door frame and handle
- Natural eco-friendly refrigerant
- Mounted on universal wheels for easy positioning



AMBIENT 38°C

LG-600BGBM

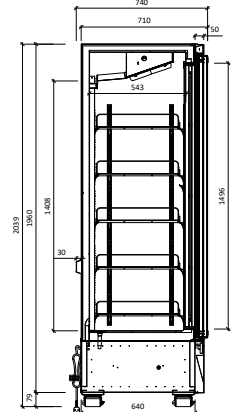
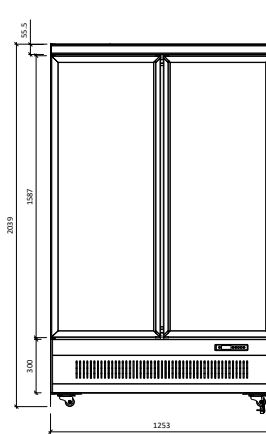
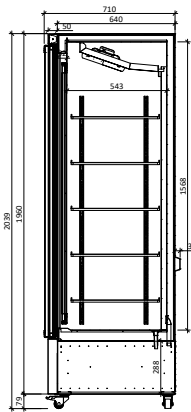
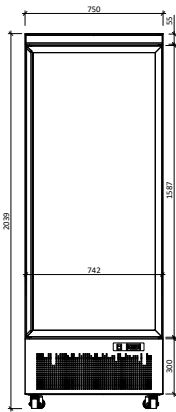

LG-1500BGBM

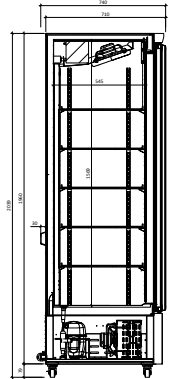
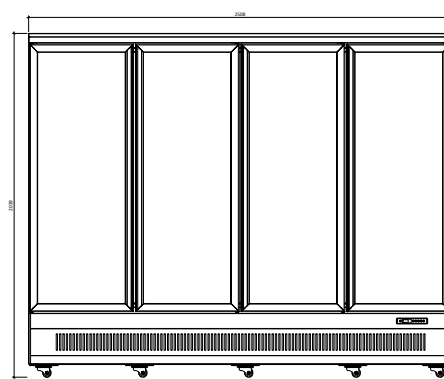
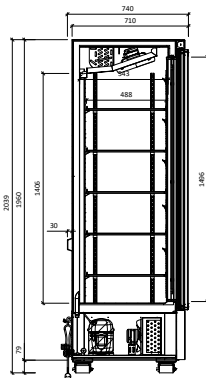
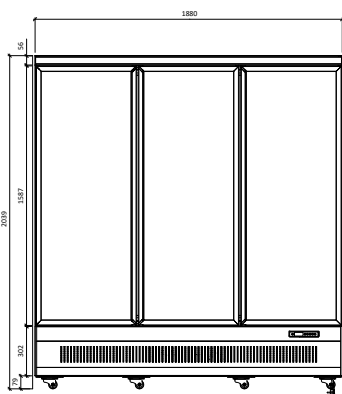

Code	Doors	GEMS Star Rating	Gross Capacity (L)	Net Capacity (L)	Dimensions (WxDxH mm)	Weight (kg)	Temp. Range °C	Ambient/ RH%	Voltage	Power (W/A)
LG-600BGBM	1	8	636	579	750x740x2039	130	+2 to +8	38/65	240	460/10
LG-1000BGBM	2	8	1117	1013	1253x740x2039	179	+2 to +8	38/65	240	460/10
LG-1500BGBM	3	6	1718	1552	1880x740x2039	207.5	+2 to +8	38/65	240	700/10
LG-2200BGBM	4	6	2319	2092	2508x740x2039	360	+2 to +8	38/65	240	920/10

Glass Door Supermarket Freezers



- Forced air circulation for consistent freezing
- Adjustable shelves for flexible storage
- Interior LED lighting for clear visibility
- Triple glazed tempered glass doors
- Self-closing doors with integrated locks
- Self-evaporating drip tray
- Powder coated interior for durability
- Aluminium door frame and handle
- Natural eco-friendly refrigerant
- Mounted on universal wheels for easy movement



LG-600BGBMF/E

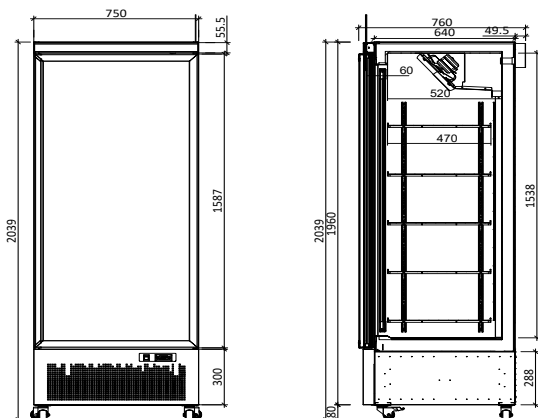

LG-1000BGBMF / LG-1000BGBMF/E

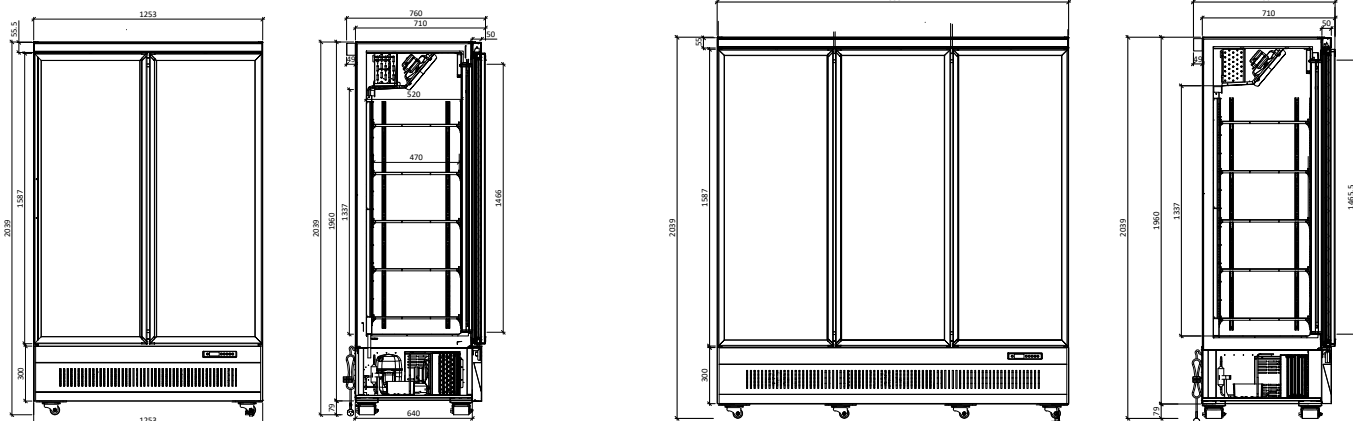

Code	Doors	GEMS Star Rating	Gross Capacity (L)	Net Capacity (L)	Dimensions (WxDxH mm)	Weight (kg)	Temp. Range °C	Ambient/ RH%	Voltage	Power (W/A)
LG-1000BGBMF	2	2	1043	897	1253x760x2039	240	-22 to -18	25/60	240	1205/10
LG-1500BGBMF	3	2	1618	1382	1880x760x2039	305	-22 to -18	25/60	240	1580/15
Lower Energy Consumption Range										
LG-600BGBMF/E	1	4	580	390	750x740x2039	150	-22 to -18	25/60	240	600/10
LG-1000BGBMF/E	2	3	1006	897	1253x760x2039	240	-22 to -18	25/60	240	1205/10
LG-1500BGBMF/E	3	3	1563	1382	1880x760x2039	304	-22 to -18	25/60	240	1280/10

Upright Double Glass Door Fridges



- Slim Aluminium glass door frame for better product presentation
- Stainless steel inner bottom for hygienic food storage and easy maintenance
- Illuminated LED light box for advertising
- Double glazing
- Hinged self-closing tempered glass door
- Streamlined operation
- LED lighting in canopy and inside cabinet
- Frost free
- Digital thermostat
- Fan force cooling system
- Top mount design
- Natural and eco-friendly refrigerant



AMBIENT 32°C

LG-1006D / LG-1006D/E

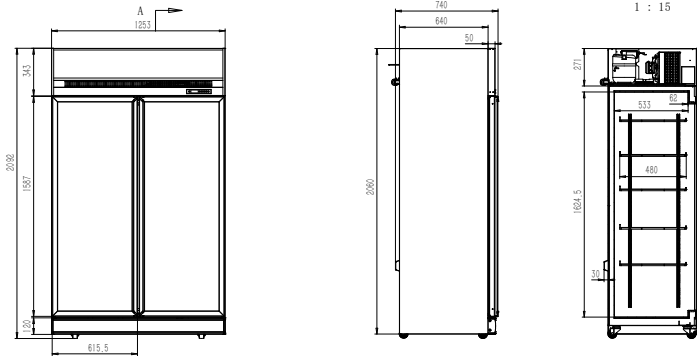

LG-1563D / LG-1563D/E

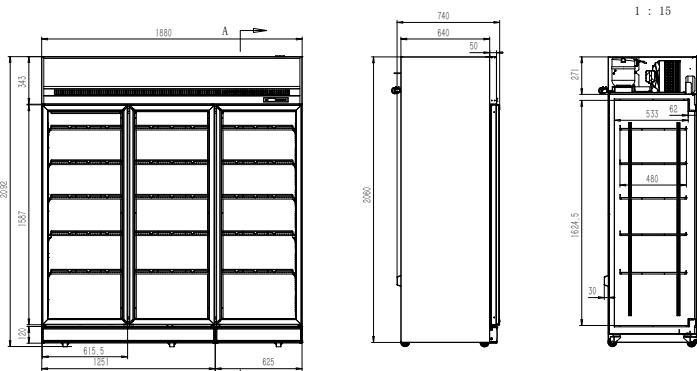

LG-2121D/E

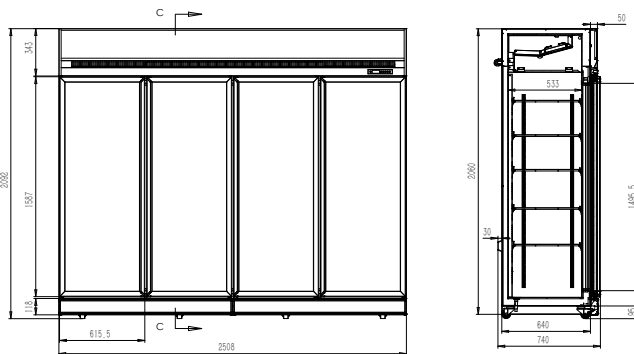

Code	Doors	Gross Capacity (L)	Net Capacity (L)	Ext. Dimensions (WxDxH mm)	Int. Dimensions (WxDxH mm)	Weight (kg)	Temp. Range °C	Ambient/ RH%	Voltage	Power (W/A)
LG-1006D	2	1006	702	1253x760x2092	1163x595x1625	154	+2 to +5	32/60	240	450/10
LG-1563D	3	1563	1090	1880x760x2092	1790x595x1625	204	+2 to +5	32/60	240	820/10
LG-2121D	4	2121	TBA	2508x760x2092	2418x595x1625	320	+2 to +5	32/60	240	1150/10

Upright Double Glass Door Freezers



- Slim Aluminium glass door frame for better product presentation
- Stainless steel inner bottom for hygienic food storage and easy maintenance
- Illuminated LED light box for advertising
- 3 layer glass: inside layer tempering, middle layer Low-E glass and outside layer heating glass
- Hinged self-closing door
- Streamlined operation
- Natural and eco-friendly refrigerant
- LED lighting in canopy and inside cabinet
- Auto-Defrost
- Digital thermostat
- Fan force cooling system
- Top mount design



LG-1006DF / LG-1006DF/E

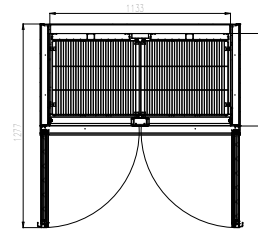
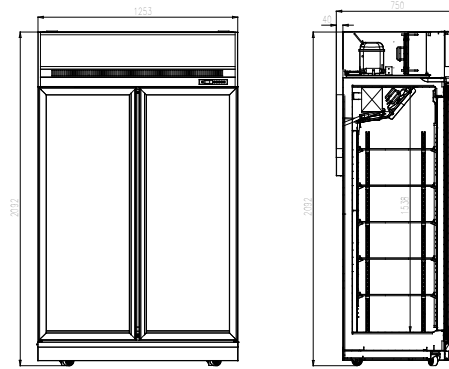

LG-1563DF / LG-1563DF/E

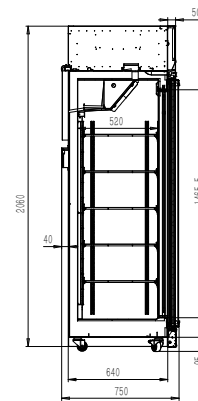
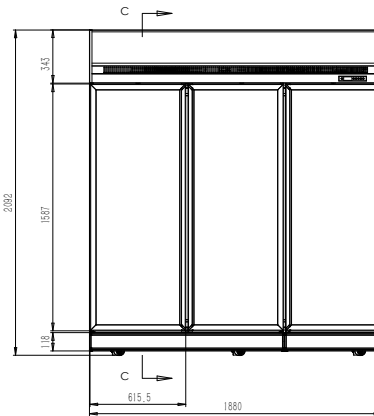

LG-2121DF/E

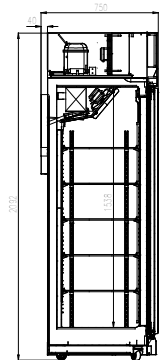
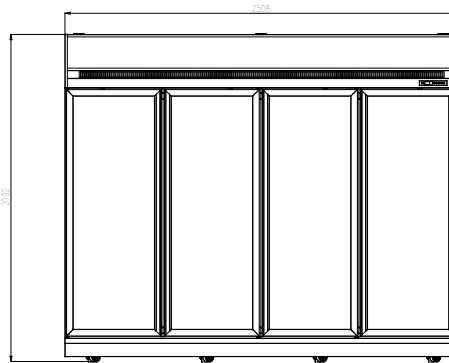

Code	Doors	Gross Capacity (L)	Net Capacity (L)	Ext. Dimensions (WxDxH mm)	Int. Dimensions (WxDxH mm)	Weight (kg)	Temp. Range °C	Ambient/ RH%	(V)	Power (kW/A)
LG-1006DF	2	1006	702	1253x750x2092	1133x580x1538	234	-22 to -18	25/60	240	1.226/15
LG-1563DF	3	1563	1090	1880x750x2092	1760x580x1538	323	-22 to -18	25/60	240	1.85/15
Lower Energy Consumption Range										
LG-1006DF/E	2	1006	702	1253x750x2092	1133x580x1538	264	-22 to -18	25/60	240	1.205/10
LG-1563DF/E	3	1563	1090	1880x750x2092	1760x580x1538	373	-22 to -18	25/60	240	1.28/10
LG-2121DF/E	4	2121	TBA	2508x750x2092	2388x580x1538	445	-22 to -18	25/60	240	2.533/15

Stainless Steel Upright Static Fridges



- 50mm high density insulation, CFC & HCFC free
- Stainless Steel exterior
- Digital temp. control & read-out
- Locking doors
- Castors on rear adjustable legs in front
- Internal corners are rounded for hygiene & easy cleaning
- Refrigerated into fix shelves for even cooling
- Regular defrosting is necessary
- Static Cooling for fridge, Static Cooling with fan for freezer
- Recessed Door Handle
- Natural and eco-friendly refrigerant



XR200SS

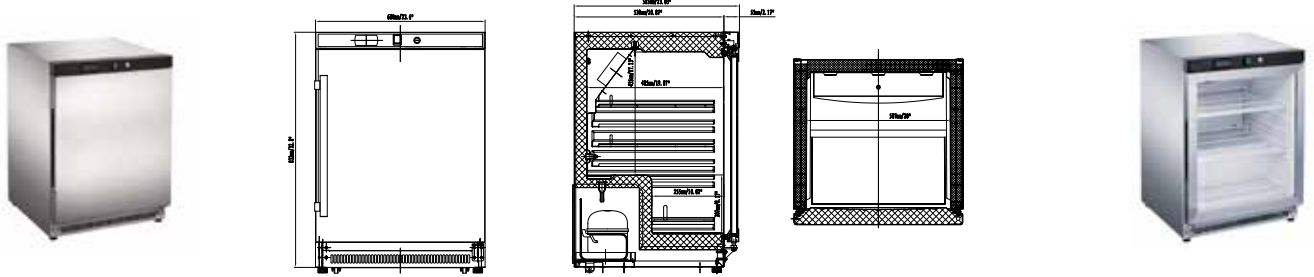

XR400SS

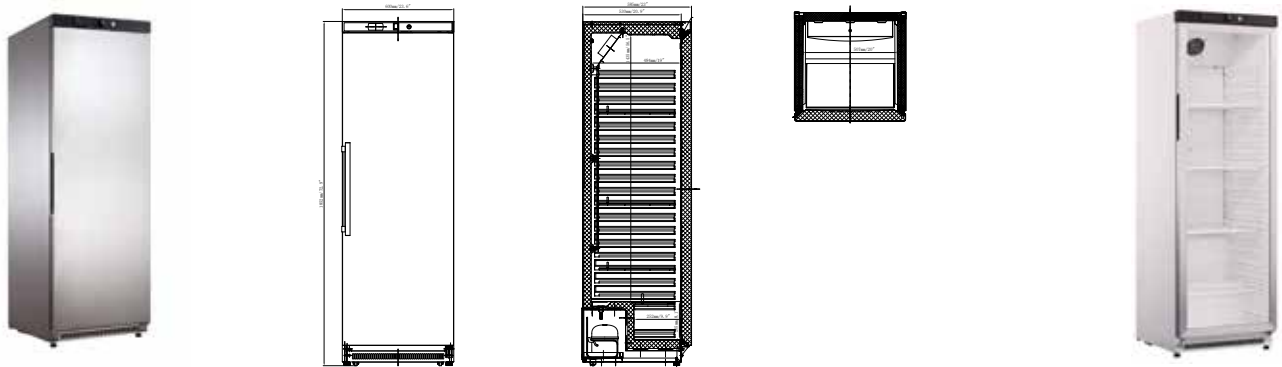

XR600SS

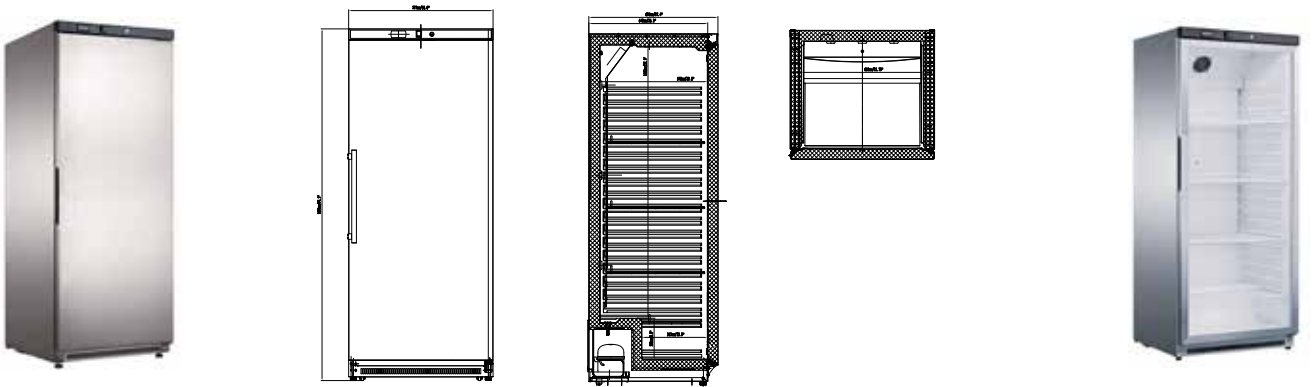

Code	GEMS Star Rating	Gross Capacity (L)	Net Capacity (L)	Shelf	Dimensions (WxDxH mm)	Weight (kg)	Temp. Range °C	Ambient/ RH%	Voltage	Power (W/A)
S/S Door Fridges										
XR200SS	6	130	113	2	600x585x850	37	-2 to +8	30 / 55	240	198/10
XR400SS	4	368	357	4	600x585x1850	61	-2 to +8	30 / 55	240	300/10
XR600SS	6	588	554	4	777x695x1890	79	-2 to +8	30 / 55	240	442/10
Glass Door Fridges										
XR200SG	10	136	113	2	600x585x850	44	-2 to +8	25/ 60	240	205/10
XR400SG	8	386	379	4	600x585x1850	70	-2 to +8	25/ 60	240	372/10
XR600SG	10	613	573	4	777x695x1890	95	-2 to +8	25/ 60	240	462/10

Stainless Steel Upright Static Freezers



- 60mm high density insulation, CFC & HCFC free
- Stainless Steel exterior
- Digital temp. control & read-out
- Locking doors
- Rear castors
- Triple glazed Low-E doors for freezers with heated filament for clear viewing
- Rounded internal corners for hygiene & easy cleaning
- Refrigerated into fixed shelves for even cooling
- Front adjustable legs
- Regular manual defrosting is necessary
- Recessed Door Handle
- Natural and eco-friendly refrigerant



Code	GEMS Star Rating	Gross Capacity (L)	Net Capacity (L)	Shelves	Dimensions (WxDxH mm)	Weight (kg)	Temp. Range °C	Ambient/ RH%	(V)	Power (W/A)
S/S Door Freezers										
XF200SS	6	108	92	3	600x585x850	37	-22 to -18	30 / 55	240	302/10
XF400SS	6	325	304	6	600x585x1850	61	-22 to -18	30 / 55	240	384/10
XF600SS	7	580	538	6	777x695x1890	81	-22 to -18	30 / 55	240	450/10
Glass Door Freezers										
XF200SG	4	114	101	3	600x585x850	48	-22 to -18	25/ 60	240	332/10
XF400SG	6	343	326	6	600x585x1850	80	-22 to -18	25/ 60	240	478/10
XF600SG	5	605	568	6	777x695x1890	106	-22 to -18	25/ 60	240	656/10

Supermarket Island Freezer/Chiller



Setting a new standard in Supermarket and Convenience Store refrigeration, our supermarket island chillers provide a range of high quality long lasting cabinets and displays using state of the art technology in ventilated air circulation, high visibility LED lights, maximum product exposure with minimum floor space.



Designed to promote your products, these supermarket islands give the retailer the edge in display and merchandising solutions, brilliantly lit, energy efficient, low maintenance customer friendly cabinets put the spotlight where it should be, on the merchandise.

- Temp. control with display
- LED Lighting
- Danfoss compressor
- Static cooling system
- Digital thermostat
- Auto defrost with no build up of ice
- Freezer -22 to -18°C

ZCD-E185S

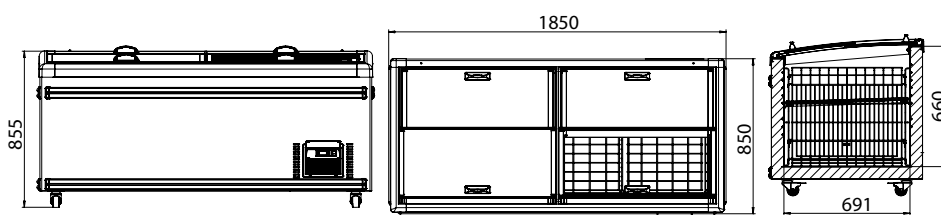

ZCD-L250S

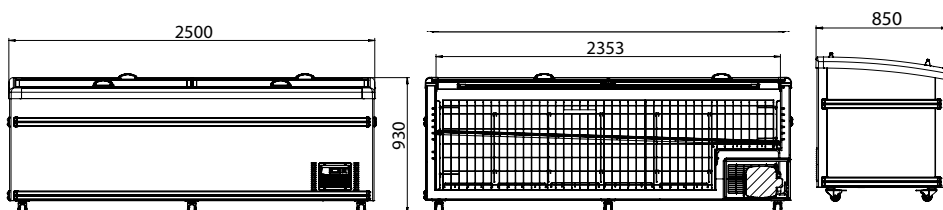

Code	Gross Capacity (L)	Dimensions (WxDxH mm)	Weight (kg)	Temperature Range °C	Ambient/ RH%	Voltage	Power (W/A)
ZCD-E185S	630	1850x850x855	130	-1 to +4 / -22 to -18	32/60	240	790/10
ZCD-L250S	1040	2500x850x870	165	-1 to +4 / -22 to -18	32/60	240	1040/10

Merchant Shelf - can fit in the middle of the chest freezer

ZCD-L210S-SVP	Side ventilation panel	790x160mm
ZCD-L210S-TVP	Top ventilation panel	2100x190mm
ZCD-L250S-TVP	Top ventilation panel	2500x190mm

Supermarket Island Freezer



- R290 natural refrigerant
- 70mm thickness insulation
- Equipped with collision stopper
- Adjustable feet
- LED lighting
- Low-E, tempered glass
- Increase display area
- Castors
- Digital thermostat
- Temp. control with display
- Equipped with storage mesh or full baskets
- Static cooling system with auto defrost
- Optional manual defrosting models available on request. Ideal for ice cream storage



ZCD-E185G

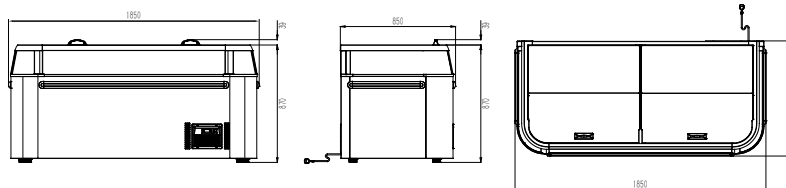

ZCD-L145G

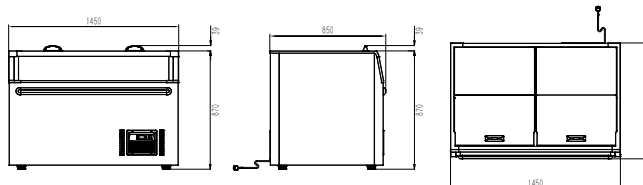

ZCD-L210G

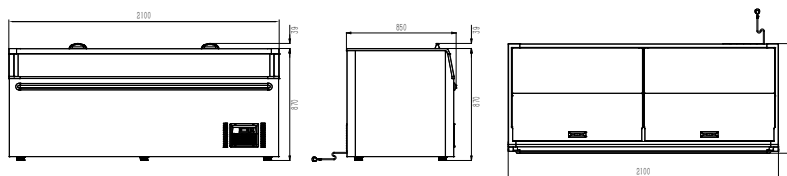

ZCD-L250G

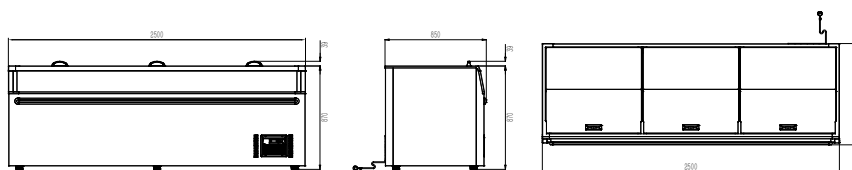

Code	Gross Capacity (L)	Net Capacity (L)	Door	Shelves	Dimensions (WxDxH mm)	Weight (kg)	Temp. Range °C	Ambient/ RH%	Voltage	Power (W/A)
ZCD-E185G	745	523	2	3	1850x850x870	129	-22 to -18	25/60	240	562/10
ZCD-L145G	575	402	2	2	1450x850x870	101	-22 to -18	25/60	240	727/10
ZCD-L210G	900	646	2	4	2100x850x870	136	-22 to -18	25/60	240	721/10
ZCD-L250G	1105	796	3	5	2500x850x870	153	-22 to -18	25/60	240	960/10

Heavy Duty Chest Freezers with Glass Sliding Lids



- Energy saving fan for improved efficiency
- Quick and deep freezing performance
- Efficient compressor with low noise operation
- Digital temperature control

- LED internal light
- Tempered LOW-E sliding glass lids
- Door lock for added security
- Removable baskets included
- Manual defrost system
- Castors for easy positioning

- Aluminium & ABS cabinet frame with aluminium liner
- Natural refrigerant



WD256G

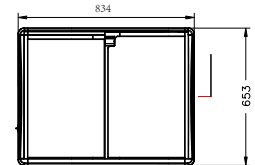
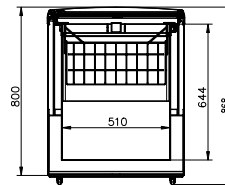
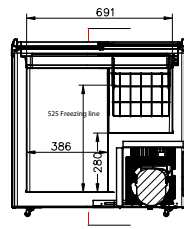

WD336G

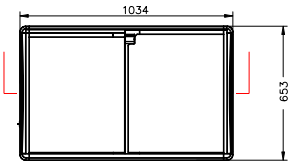
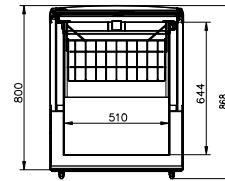
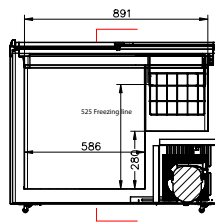

WD396G

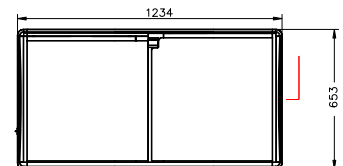
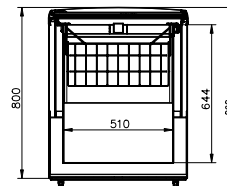
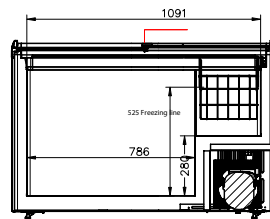

Code	GEMS Star Rating	Gross Capacity (L)	Basket	Dimensions (WxDxH mm)	Weight (kg)	Temp. Range °C	Ambient/ RH%	Voltage	Power (W/A)
WD256G	6	256	3	834x653x868	43	-22 to -18	32/55	240	200/10
WD336G	5	336	4	1034x653x868	47	-22 to -18	32/55	240	220/10
WD396G	6	396	5	1234x653x868	53	-22 to -18	32/55	240	250/10

Heavy Duty Chest Freezers with Glass Sliding Lids



- Quick and deep freezing
- Efficient compressor with low noise
- Digital temperature control
- LED internal light
- LOW-E tempered sliding glass lids
- Door lock for security
- Removable baskets included
- Manual defrost
- Castors for easy movement
- Aluminium & ABS cabinet frame
- Aluminium liner with natural refrigerant



WD456G

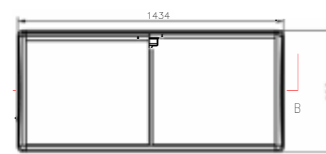
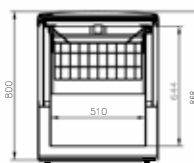
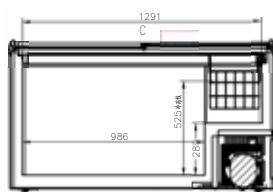

WD516G

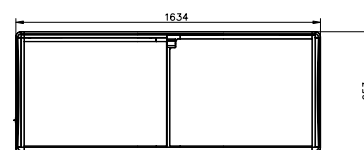
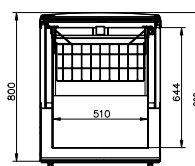
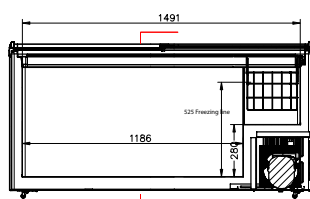

WD586G

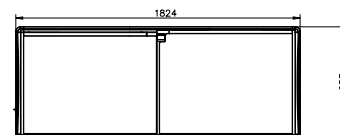
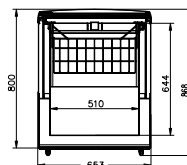
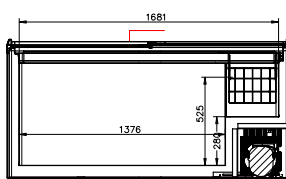

Code	GEMS Star Rating	Gross Capacity (L)	Basket	Dimensions (WxDxH mm)	Weight (kg)	Temp. Range °C	Ambient/ RH%	Voltage	Power (W/A)
WD456G	5	456	6	1434x653x868	61	-22 to -18	32/55	240	270/10
WD516G	5	516	7	1634x653x868	65	-22 to -18	32/55	240	280/10
WD586G	6	586	8	1824x653x868	72	-22 to -18	32/55	240	320/10

Premium S/S Work Tables with Undershef

- Specially designed for quick, simple assembly
- 1.2mm 304 grade stainless steel top
- 600mm or 700mm deep options
- Solid S/S 'U' channel reinforcement (1.2mm)
- Full-size 1.2mm S/S undershef
- Adjustable S/S feet or castors
- Instruction manual & tools included
- Hygienic, durable & easy to clean
- Flat packed for easy transport
- Optional S/S bolt-down feet available

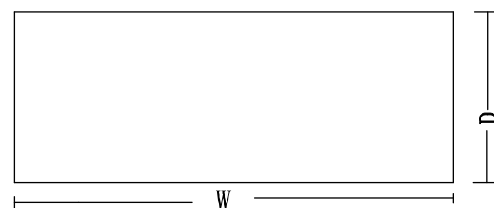
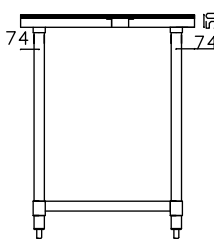
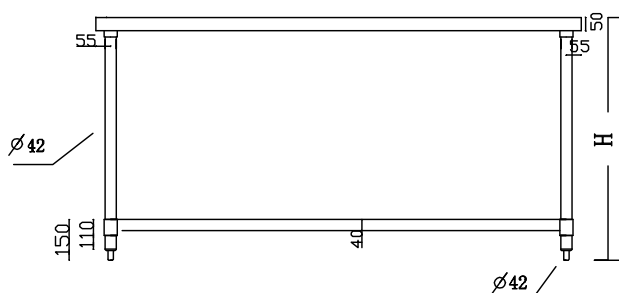

Code	Dimensions (WxDxH mm)
600Dx900H with Adjustable S/S Feet	
WB6-0600/A	600x600x900
WB6-0900/A	900x600x900
WB6-1200/A	1200x600x900
WB6-1500/A	1500x600x900
WB6-1800/A	1800x600x900
WB6-2100/A	2100x600x900
WB6-2400/A	2400x600x900

Mobile Benches

Code	Dimensions (WxDxH mm)
700Dx900H with Castors – Front 2 Castors Lockable	
WBM7-0600/A	600x700x900
WBM7-0900/A	900x700x900
WBM7-1200/A	1200x700x900
WBM7-1500/A	1500x700x900
WBM7-1800/A	1800x700x900
WBM7-2100/A	2100x700x900
WBM7-2400/A	2400x700x900

Code	Dimensions (WxDxH mm)
700Dx900H with Adjustable S/S Feet	
WB7-0600/A	600x700x900
WB7-0800/A	800x700x900
WB7-0900/A	900x700x900
WB7-1000/A	1000x700x900
WB7-1200/A	1200x700x900
WB7-1500/A	1500x700x900
WB7-1800/A	1800x700x900
WB7-2100/A	2100x700x900
WB7-2400/A	2400x700x900

Premium S/S Work Tables with Undershef & Splashback

- 600mm or 700mm deep configurations
- 1.2mm thick 304 grade stainless steel top
- Solid 1.2mm S/S 'U' channel reinforcement under benchtop
- Full-size 1.2mm 304 grade S/S undershef
- 150mm high x 30mm deep 304 S/S splashback
- Adjustable stainless steel bullet feet
- Heavy-duty commercial construction
- Instruction manual & tools supplied
- Hygienic, corrosion-resistant & easy to clean
- Flat packed for fast, simple assembly
- Optional stainless steel bolt-down feet available

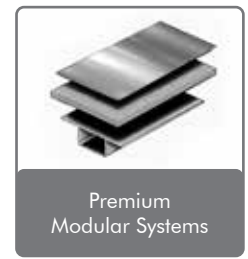
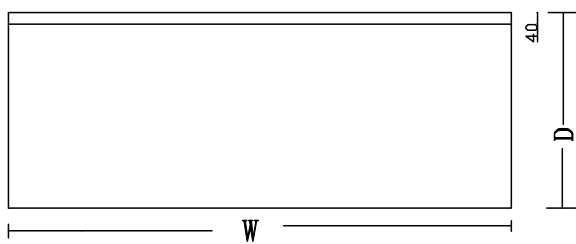
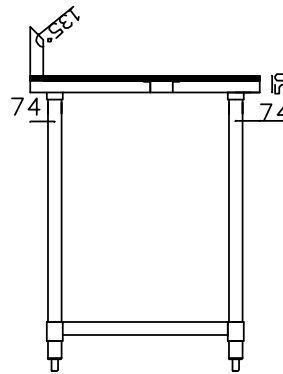
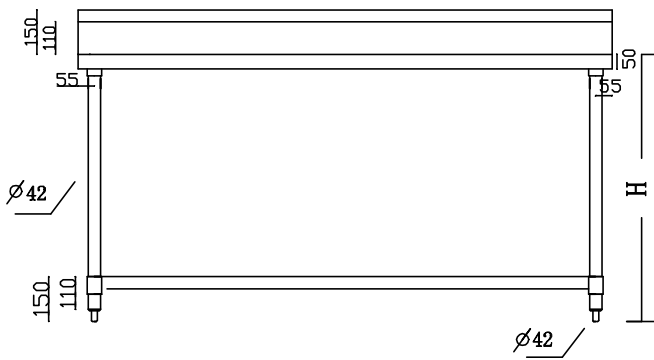

Code	Dimensions (WxDxH mm)
600Dx900H with Adjustable S/S Feet	
WBB6-0600/A	600x600x900
WBB6-0900/A	900x600x900
WBB6-1200/A	1200x600x900
WBB6-1500/A	1500x600x900
WBB6-1800/A	1800x600x900
WBB6-2100/A	2100x600x900
WBB6-2400/A	2400x600x900

Code	Dimensions (WxDxH mm)
700Dx900H with Adjustable S/S Feet	
WBB7-0300/A	300x700x900
WBB7-0450/A	450x700x900
WBB7-0600/A	600x700x900
WBB7-0800/A	800x700x900
WBB7-0900/A	900x700x900
WBB7-1000/A	1000x700x900
WBB7-1200/A	1200x700x900
WBB7-1500/A	1500x700x900
WBB7-1800/A	1800x700x900
WBB7-2100/A	2100x700x900
WBB7-2400/A	2400x700x900

S/S Sink Benches with Pot Shelf

- 1.2mm lined 304 grade tops
- 600mm / 700mm deep
- Solid 'U' channel reinforcement under, 1.2mm thick
- Legs S/S adjustable feet or castors
- Specially designed for quick & simple assembly
- Hygienic & easy to clean
- Instruction manual & tools included
- Flat packed for easy self-assembly
- Locking drawers available
- Pot Undershelves 1.0mm 304 grade S/S (18/8); BA finish
- Outer frame tubes: 1.0mm S/S
- 5 x Inner tubes: 1mm S/S
- Splashback 150mm high; 30mm deep
- Sink Bowls 1.2mm 304 grade S/S (18/8) with Hairline finish
- Sink bowls punched, polished inside & out
- 90mm Ø drain hole
- S/S Bolt down feet available

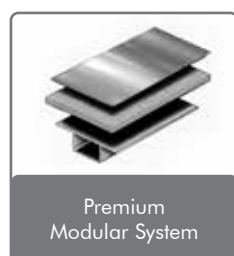

Code	Dimensions (WxDxH mm)
600Dx900H – Single Sink 400x400x300	
SSB6-1200L/A	1200x600x900
SSB6-1200R/A	1200x600x900
SSB6-1200C/A	1200x600x900
SSB6-1500L/A	1500x600x900
SSB6-1500R/A	1500x600x900
SSB6-1500C/A	1500x600x900
SSB6-1800L/A	1800x600x900
SSB6-1800R/A	1800x600x900
SSB6-2400L/A	2400x600x900
SSB6-2400R/A	2400x600x900

Code	Dimensions (WxDxH mm)
700Dx900H – Single Sink 450x450x300	
SSB7-1200L/A	1200x700x900
SSB7-1200R/A	1200x700x900
SSB7-1200C/A	1200x700x900
SSB7-1500L/A	1500x700x900
SSB7-1500R/A	1500x700x900
SSB7-1500C/A	1500x700x900
SSB7-1800L/A	1800x700x900
SSB7-1800R/A	1800x700x900
SSB7-1800C/A	18400x700x900

Code	Dimensions (WxDxH mm)
600Dx900H – Double Sink 2x 400x400x300	
DSB6-1000/A	1000x600x900
DSB6-1200C/A	1200x600x900
DSB6-1500L/A	1500x600x900
DSB6-1500R/A	1500x600x900
DSB6-1500C/A	1500x600x900
DSB6-1800L/A	1800x600x900
DSB6-1800R/A	1800x600x900
DSB6-1800C/A	1800x600x900

Code	Dimensions (WxDxH mm)
700Dx900H – Double Sink 2x 450x450x300	
DSB7-1200C/A	1200x700x900
DSB7-1500L/A	1500x700x900
DSB7-1500R/A	1500x700x900
DSB7-1500C/A	1500x700x900
DSB7-1800L/A	1800x700x900
DSB7-1800R/A	1800x700x900
DSB7-1800C/A	1800x700x900
DSB7-2100L/A	2100x700x900
DSB7-2100R/A	2100x700x900
DSB7-2100C/A	2100x700x900
DSB7-2400L/A	2400x700x900
DSB7-2400R/A	2400x700x900
DSB7-2400C/A	2400x700x900

S/S Sink Benches with Pot Shelf

-SSBL

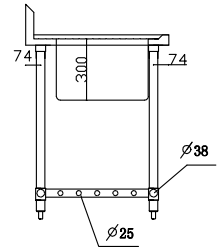
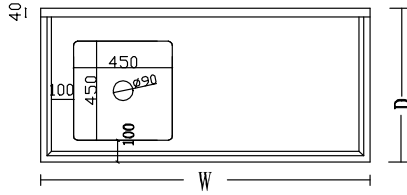
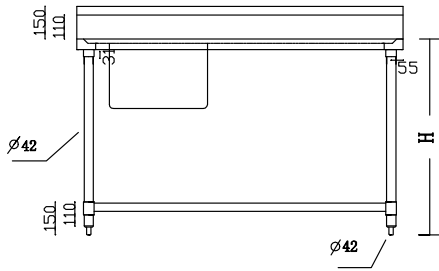

-SSBR

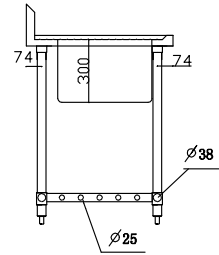
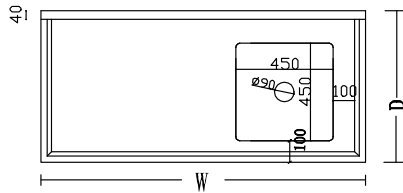
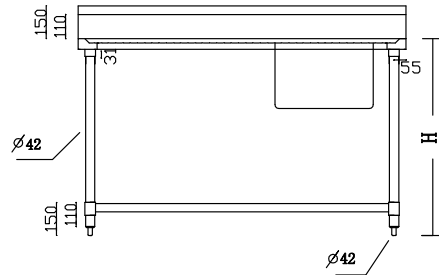

-SSBC

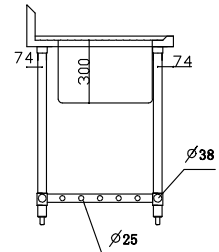
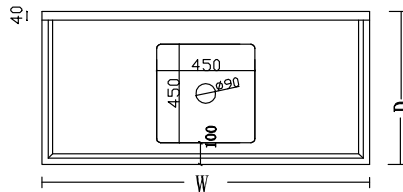
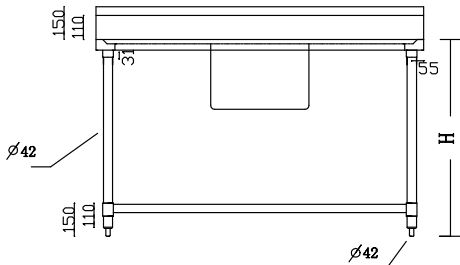

-DSBL

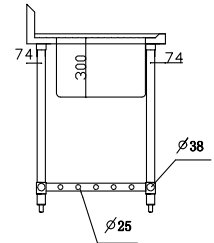
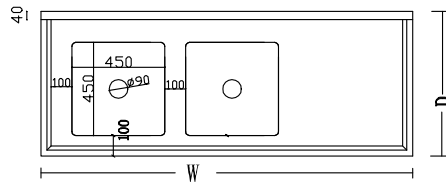
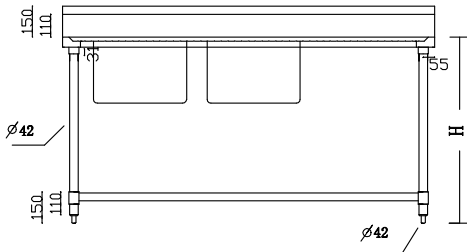

-DSBR

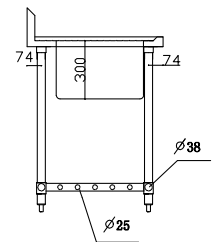
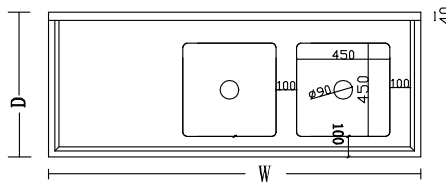
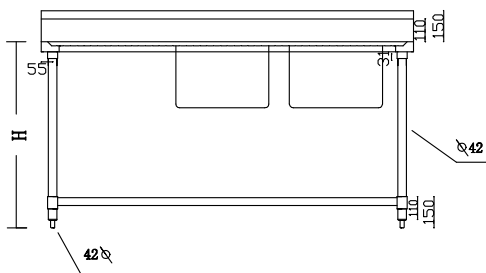

-DSBC

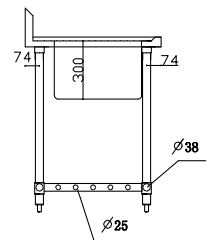
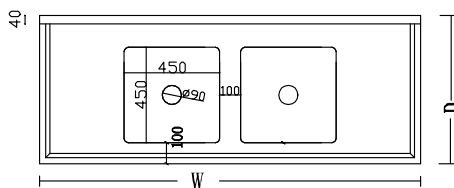
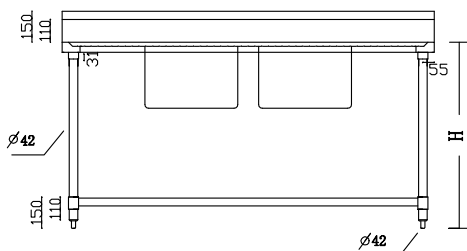

S/S Mop Sinks & Sinks

- 90mmØ drain holes
- Tapware not included

FMS-H

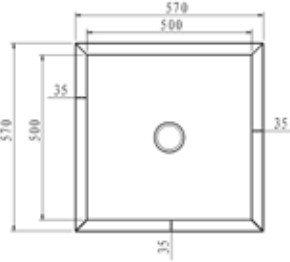
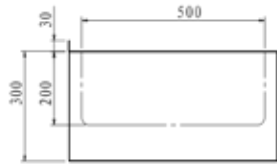
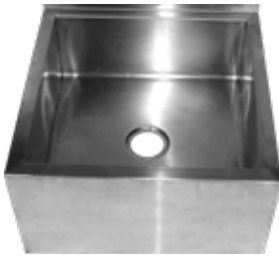

SMS-H

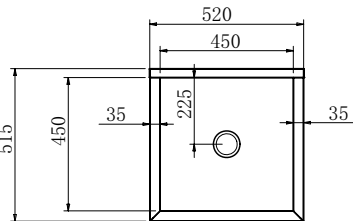
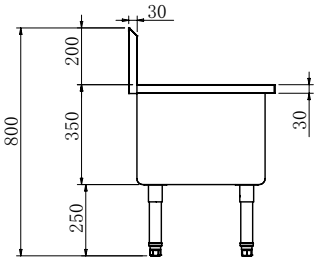

SKBEN01-1818N



Code	Description	Dimensions (WxDxH mm)
FMS-H	Floor Mop Sink	570x570x300
SMS-H	Single Mop Sink	520x515x800
SKBEN01-1818N	Single Sink	584x610x1120

S/S Hand Basin

MODULAR SYSTEMS



Code	Dimensions (WxDxH mm)
SHY-2N	435x368x140+30mm

Mop / Cleaning Sink

- 1.5mm S/S fabricated bowl and splashback
- Welded steel grate has six bars for stable support of buckets while filling and draining
- 3.5" drain basket included



Code	Dimensions (WxDxH mm)
HCS-05	460x560x688

Mop / Cleaning Sink



Code	Dimensions (WxDxH mm)
HCS-AB	530x470x250+230

4 Tier Shelving Kits

Multipurpose wire shelving system, the perfect storage solution for food, pans, linen, crockery and much more. Complete set includes 1880mm high posts with 4 shelves & clips.

- Black plasticised shelving & posts
- Suitable for cool rooms & freezers
- TEN YEAR GUARANTEE
- High quality, attractive and robust
- Easy height-adjustable corner lock clips
- Load Rating: 150kg/shelf
- Meets appropriate health dept. requirements
- Comes standard with bullet feet
- Available 910 & 2184mm High
- Extra Shelves available



Code	Dimensions (WxDxH mm)
457mm Shelf Depth	
B18/24	610x457x1880
B18/30	760x457x1880
B18/36	915x457x1880
B18/42	1067x457x1880
B18/48	1220x457x1880
B18/54	1372x457x1880
B18/60	1525x457x1880
B18/72	1830x457x1880

Code	Dimensions (WxDxH mm)
610mm Shelf Depth	
B24/24	610x610x1880
B24/30	760x610x1880
B24/36	915x610x1880
B24/42	1067x610x1880
B24/48	1220x610x1880
B24/54	1372x610x1880
B24/60	1525x610x1880
B24/72	1830x610x1880

Accessories & Options



Code	Description
CASTORWITHOUTBRAKE	Castor without brake
CASTORWITHBRAKE	Castor with brake
POST-CAP	Post Cap
LOCKINGCLIP	Locking Clip
N-CLIP	Shelf Clip
WSP008	Post Clamp
B-POST/910MM	Set of 4 Posts – 910mm High
B-POST/1880MM	Set of 4 Posts – 1880mm High
B-POST/2184MM	Set of 4 Posts – 2184mm High

Poly Coated Steel with Vented Shelves kits

- Designed for multiple combinations
- Made of innovative high-strength composite materials
- Smooth, easy-to-clean surface
- Notch-embedded post
- Shelf plate is added with the antibacterial agent
- Buckle design makes installation and adjustment easier
- Can be used under low temperature from -38°C to 88°C
- Suitable for wet kitchen
- Mould-proof, Fungus-proof and Rust-proof
- Environment Friendly
- The shelf plates can be washed in the dishwasher
- Load capacity for 760-1220mm long starter unit is 250kg each shelf
- Load capacity for 1370-1825mm long starter unit is 200kg each shelf
- Load capacity for corner unit is 200kg each shelf
- Capacity of whole set of mobile unit is 300kg
- Adjustable feet



Code	Dimensions (WxDxH mm)	Add On Unit
4 Teir Vented Shelving Kit – 455mm Deep		
PCU18/30	760x455x1800	PCA18/30
PCU18/36	910x455x1800	PCA18/36
PCU18/42	1060x455x1800	PCA18/42
PCU18/48	1220x455x1800	PCA18/48
PCU18/54	1370x455x1800	PCA18/54
PCU18/60	1525x455x1800	PCA18/60
PCU18/72	1825x455x1800	PCA18/72

Code	Dimensions (WxDxH mm)	Add On Unit
4 Teir Vented Shelving Kit – 610mm Deep		
PCU24/30	760x610x1800	PCA24/30
PCU24/36	910x610x1800	PCA24/36
PCU24/42	1060x610x1800	PCA24/42
PCU24/48	1220x610x1800	PCA24/48
PCU24/54	1370x610x1800	PCA24/54
PCU24/60	1525x610x1800	PCA24/60
PCU24/72	1825x610x1800	PCA24/72

Code	Description
PCU-BC	Castor with brake
PCU-NC	Castor without brake
PCU-CC	2x Corner Connectors





Supporting Australian & New Zealand convenience stores for over 50 years.

OVENS & COOKING BENCHTOP BEVERAGE DISPLAYS REFRIGERATION STAINLESS

