

# Under Bench Ice Makers



## ICE MAKER

### SN-25C



Maximum Value Output

**25** kg/24h



Storage: **15** kg



Bullet Ice  
22mmØX40mm

The SN-25C is a compact, high-hardness ice maker that produces bullet, built with a durable AISI304 stainless-steel exterior and an easy-to-reach ON/OFF switch. It features a specialised built-in spray-type evaporator to improve ice clarity and hardness, an air-cooled system, and R290 eco-friendly refrigerant. Designed for hygiene and reliability, it

includes an automatic cleaning system, automatic fault alerts, food-grade materials with international certification, and internal LED lighting.

For best-tasting ice and a longer machine lifespan, we recommend pairing it with an FHE water filter and replacing the filter cartridge regularly.



#### Compact Under-Bench Design

Space-saving footprint fits under standard benches—ideal for bars, cafés, and compact kitchens.



#### Smart Operation System

Features automatic fault alerts and simple ON/OFF controls for reliable day-to-day operation.



#### Eco-Friendly Refrigeration

R290 refrigerant delivers efficient cooling with lower environmental impact.





# SN-25C

## Under Bench Ice Makers

Fully automatic and accurate control system



Removable water filter

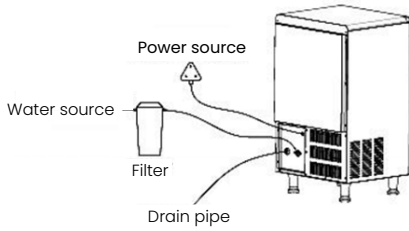

Bullet Ice

High Production Rate & Significant Storage Capacity

LDPE Ice Bin

Control Panel

Ventilation Window Panel

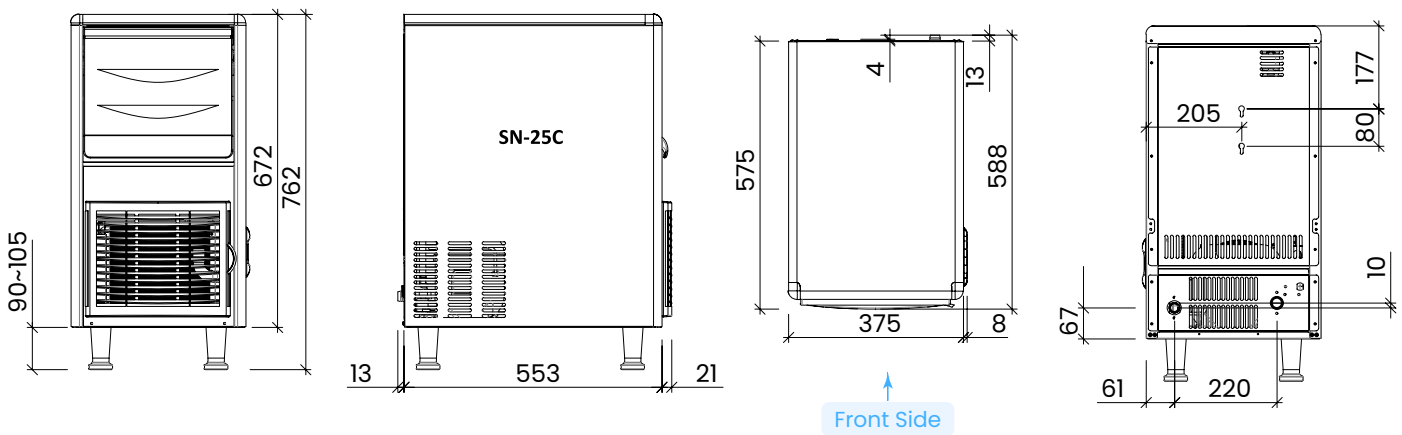

Front Side

Code	Output (kg/24hrs)	Storage (kg)	Water Consumption (kg/24hrs)	Ventilation (cm)	Dimensions (WxDxH mm)	Weight (kg)	Energy Consumption Rate (kwh/100kg ice)	GEMS Approved	Voltage	Power (W/A)
SN-25C	25	15	102	Front > 30, Rear > 20, Sides > 15	375x575x762	39	30.11	True	240	300/10

To ensure we continuously offer the best possible products, we reserve the right to modify specifications without any obligation for equipment previously or subsequently sold