

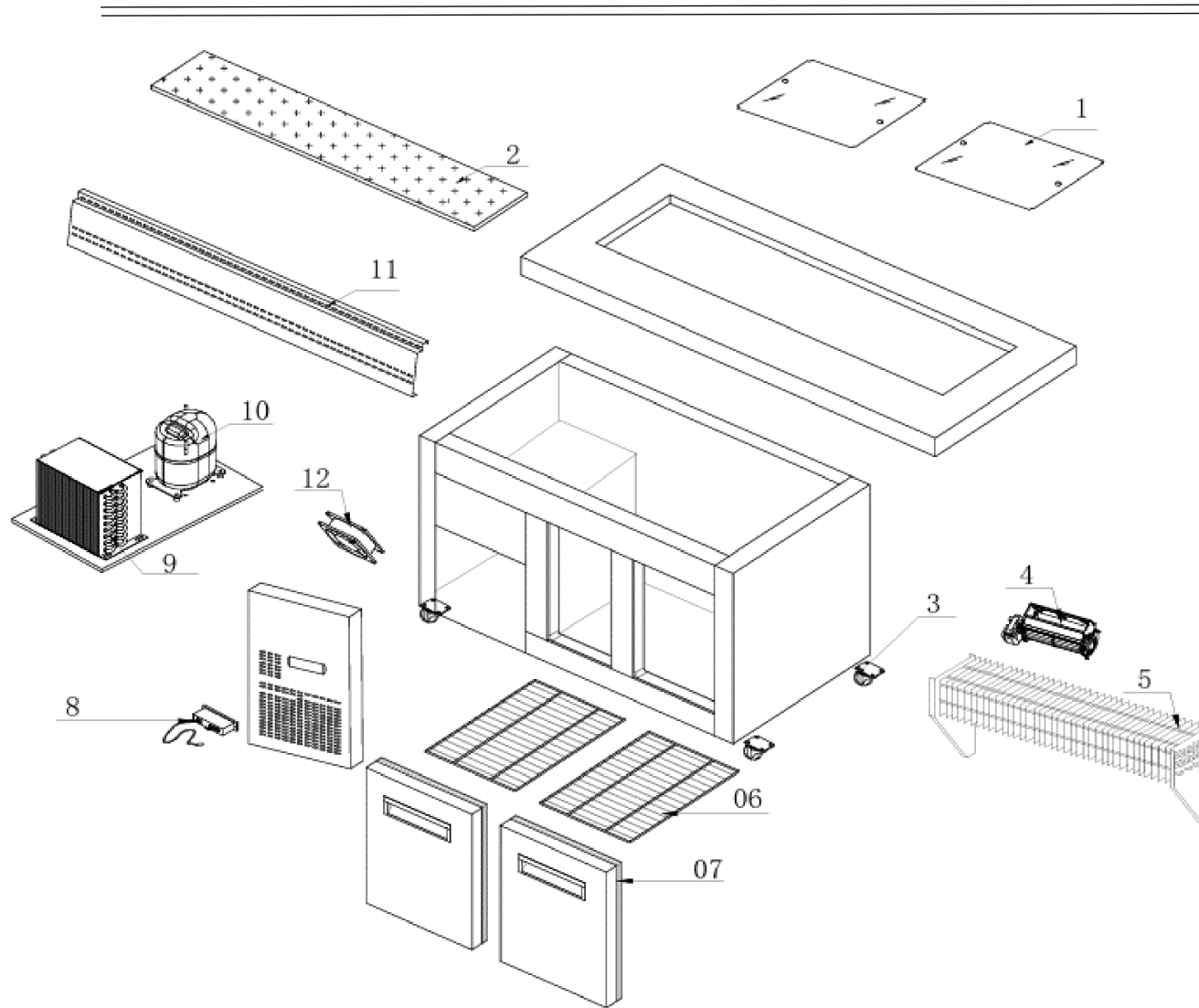

PG150FA-XB EXPLODED DIAGRAM



PG150FA-XB PARTS LIST

Item	FHE Part Code	Description	Qty	Remark	
1	1-1	PG150FA-XB-ASD557	Acrylic Sliding Door 557mm X 460mm	2	
	1-2	PG150FA-XB-ASD586	Acrylic Sliding Door 586mm X 460mm	1	
2	PG150FA-XG-CB	Chopping Board 1460mm X 220mm	1		
3	Version 1	PG150FA-XG-NC	Normal Castor 4 Inch	2	SN From 385175 to 385411
	Version 1	PG150FA-XG-BC	Brake Castor 4 Inch	2	SN From 385175 to 385411
	Version 2	PG150FE-11	Normal Castor 3 Inch	2	SN From 385778
	Version 2	PG150FE-11A	Brake Castor 3 Inch	2	SN From 385778
4	Version 1	PG150FA-XG-EF	Evaporator Fan 120mm X 120mm	3	SN From 385175 to 385411
	Version 2	PG150FA-XB-ECFF	Evaporator Cross Flow Fan Weiguang YGF60-240	1	SN From 385778
	Version 3	PG180FA-XB-EF	Evaporator Cross Flow Fan Weiguang YGF60-183	1	SN From 385778
5	PG150FA-XG-Evap	Evaporator 5 X 4 X 700	1		
6	PG150FA-XG-Shelf	Left/Right Side Shelf 462mm X 500mm	2		
7	PG150FA-XG-DG	Door Seal 495mm X 645mm	2		
8	TEMP CONT SF-102	Temp Controller SF102	1		
9	PG180FA-XB-Cond	Condenser 3 X 11 X 280	1		
10	SF15MFX	Compressor	1		

PG150FA-XB PARTS LIST

Item	FHE Part Code	Description	Qty	Remark
11		Air Duct Panel 1337mm X 200mm	1	
12	FAN-24	Fan SJ1225HA2 120mm X 120mm X 25mm 220V-240V AC 0.1A	1	
	PG150FA-XG-CBFB	Chopping Board Fixing Bracket Set		
	PG150FA-XG-CUP	Cooling Unit Panel		
	PG150FA-XG-LD	Left Door 500mm X 650mm		
	PG150FA-XG-RD	Right Door 500mm X 650mm		
	PG150FE-XG-PD	Pan Divider 535mm X 30mm		

FHE After Sales Service & Support (AU)
Phone: 1300887055
Spares Email: spares@fedservices.com.au

FHE After Sales Service & Support (NZ)
Phone: 09 415 6471
Service Email: service@fedproducts.co.nz