

CONVECT MAX

DIGITAL CONVECTION OVEN WITH GRILL





- **YXD-3DI**
Digital Control
- **YXD-3AE**
Manual Control



Note: YXD-3DI

The Convect Max is a high-performance digital convection oven built for busy commercial kitchens, bakeries, cafes, and food service environments. With a generous 62-litre capacity, it's ideal for professionals who need consistent cooking, even heat distribution, and space-saving efficiency. Designed with durability and versatility in mind, this oven includes a built-in grill function, giving chefs more control over finishing and browning. You can effortlessly switch between convection and grill functions. Whether you are baking, roasting or grilling, the oven is designed to ensure that you get perfect cooking results with ease.

Key Features

-  **Dual Round Heaters Plus High-Speed Motors With 2 Fans**
Provide more even heat distribution, suitable for frequent use and high-temperature environments
-  **Cooking Versatility**
Convection and grill functions can be easily switched by means of a change-over switch
-  **Uniform Heat Conduction**
Stainless steel baffle to generate heat more evenly
-  **Safety System**
Temperature fuse 360°C, 1 re-set button restarts the oven after overheat protection. Switches to stand by after 60 minutes of inactivity



Croissant



Bakery



Cookies



Barbeque

Product Design Overview



Brilliant LED Lighting

Interior chamber light for visibility during cooking



Uniform Heat Conduction

Stainless steel baffle to generate heat more evenly



Built-in Grill

Built-in grilling function for finishing and browning



5-Side Insulation Design

Improved energy efficiency and excellent insulation



Durable Slanted Front Glass

Double pane tempered for clear, safe display

Details

This model is designed with practicality at its core: cool-touch double-glazed glass for safety, 90° door latch access, and an interior chamber light so you can monitor the process at a glance. Whether you're baking pastries, roasting meats, or grilling vegetables.

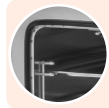

- Rounded interior corners for easier cleaning

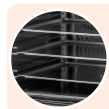

- Aluminium baking trays and wire grid, Nickel coating pan support



- Exterior body AISI430 and interior AISI201, exterior for durability



- 90° Door latch for safe, easy chamber access



Comparison

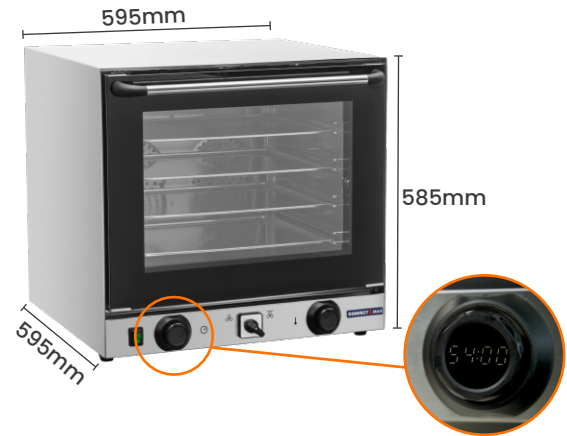

YXD-3DI Digital Control

- 01 Digital panel 2 knobs & 1 switch
- 02 1-minute cooking temperature
- 03 Switches to standby after 60 minutes of inactivity
- 04 Temperature Range: 50°C to 260°C



YXD-3AE Manual Control

- 01 3 knobs
- 02 10-minute cooking temperature
- 03 Temperature Range: 50°C to 300°C

Product Summary



YXD-3DI

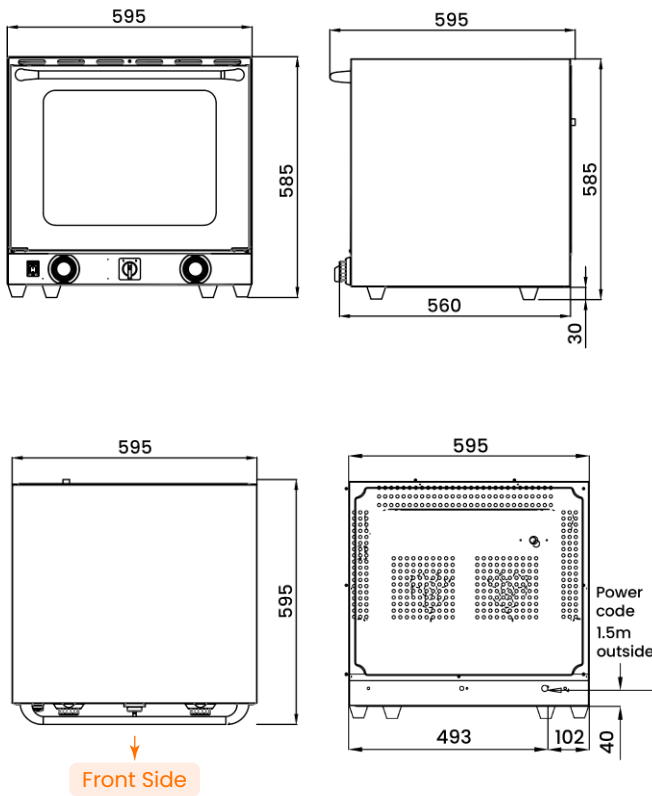

YXD-3AE

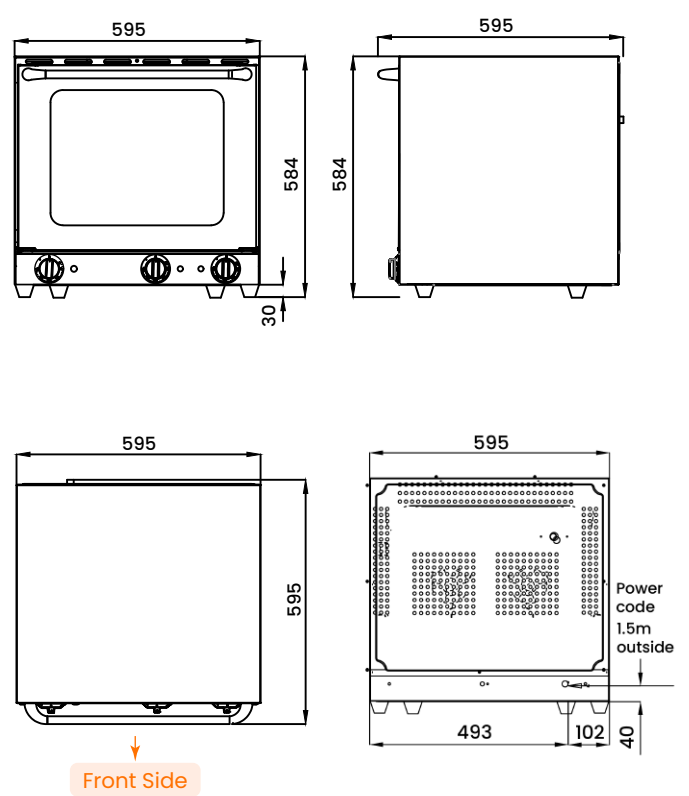

Code	Energy Consumption	Ingress Protection Class	Dimensions (W x D x H mm)	Weight (kg)	Power (kW/A)	Temperature Range	Preheating Time	Gross Capacity (L)	Net Capacity (L)
YXD-3DI	2.4kW/MJ	IPX3	595x595x585	38	2.4/10	50 to 260°C	22 min up to 260°C	62	60
YXD-3AE	2.4kW/MJ	IPX3	595x595x585	38	2.4/10	50 to 300°C	22 min up to 260°C	62	60

