



Full Glass and Solid Door Upright Stainless Steel Fridges & Freezers



XUR G V/XUR S V/XUR SFV RANGE

XURC400SFV, XURF400SFV, XURC600SFV, XURF600SFV, XURC650SFV, XURF650FV, XURC1200SFV, XURF1200SFV,
XURC600SIV, XURF600SIV, XURC1200S2V, XURF1200S2V, XURC650SIV, XURF650SIV, XURC1410S2V,
XURF1410S2V, XURC600GIV, XURF600GIV, XURC1200G2V, XURF1200G2V, XURC1410G2V, XURF1410G2V

KEY FEATURES



High-Performance Stainless Steel Cabinet

60mm thick polyurethane foam to ensure stable temperature performance even in high ambient conditions.



Excellent Gastronorm Storage Capacity

Each shelf supports GN 1/1 pans, offering maximum flexibility for foodservice storage and organization. (XURC400SFV & XURF400SFV models excluded)



Tropical Rated Cooling

Engineered for Australian conditions, with fan-forced airflow and reliable performance in ambient temperatures up to 43°C. (38°C for glass door models)



High efficiency

GEMS certified with natural refrigerants for low power consumption and eco-friendly operation.

DETAILS

High-performance stainless steel cabinet with 60mm thick polyurethane foam for superior insulation, ensuring stable temperature performance even in high ambient conditions. Features include stainless steel interior and exterior with rounded corners for easy cleaning, auto defrost. Equipped with self-closing, lockable doors with heavy-duty magnetic seals, and HFCs and CFCs-free foam insulation for eco-friendliness. Fan-forced evaporator cooling provides efficient temperature control, capable of maintaining

performance in ambient temperatures up to 38/43°C. User-friendly digital controls, internal lighting, integrated door handle for easy cleaning. Heavy-duty castors with front wheel brakes facilitate mobility and stability.

This combination of features makes these cabinets ideal for reliable, hygienic, and efficient kitchen and catering environments in challenging climate conditions.



FHE After-Sales Service and Support

AUS Phone: 1300 887 055

Email: service@fedservices.com.au

NZ Phone: 0800 081 847

Email: service@fedproducts.co.nz

XUR G V/XUR S V/XUR SFV RANGE



Fan-Forced Cooling

Reliable airflow for even internal temperatures.



Tropical Rated Build

Performs in ambient temps up to 43°C. (38°C for glass door models)



Digital Temp Controls

Easy to read and adjust for precise cooling.



Energy Saving Options

Choose split doors or LED-lit glass doors to lower power use.



GN Pan Shelving

Each shelf fits 1/1 GN pans for efficient storage. (XURC400SFV & XURF400SFV models excluded)



Integrated recessed door handle

Featuring integrated door handles, lockable self-closing doors, and a seamless design, it eliminates dirt traps.



XUR G V/XUR S V/XUR SFV RANGE



XURC400SFV / XURF400SFV

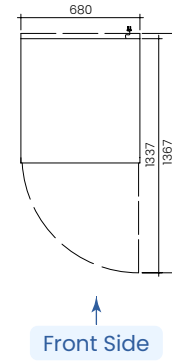
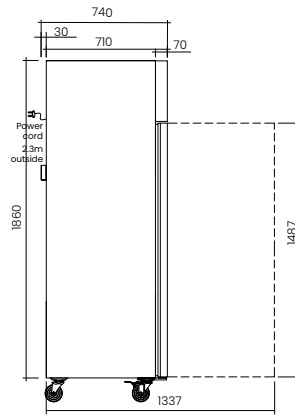
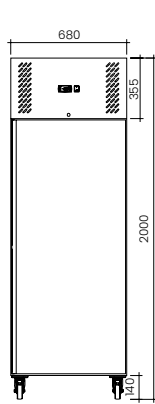

XURC650SFV / XURF650SFV

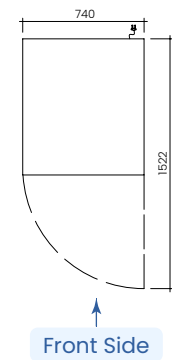
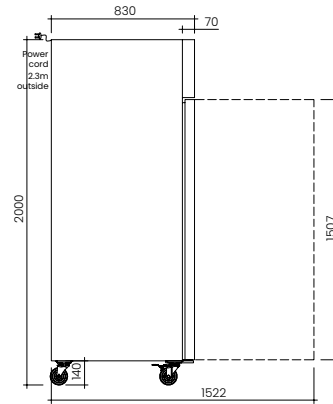
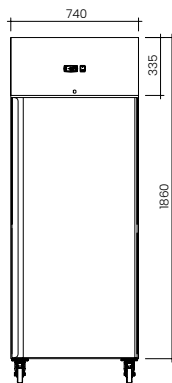

XURC600S1V / XURF600S1V

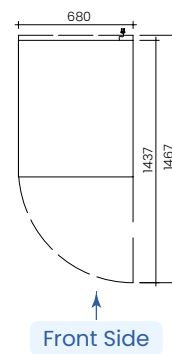
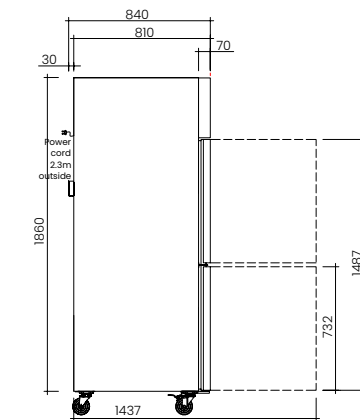
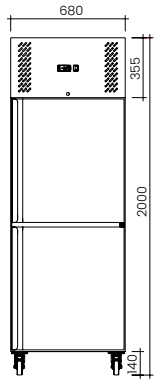

XURC650S1V / XURF650S1V

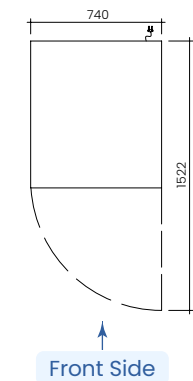
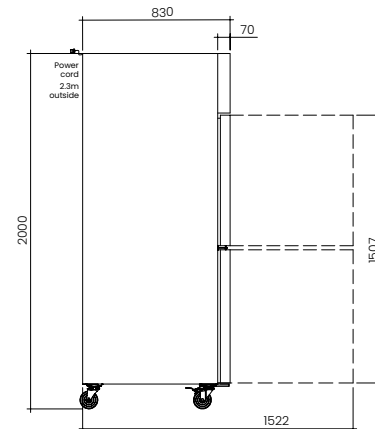
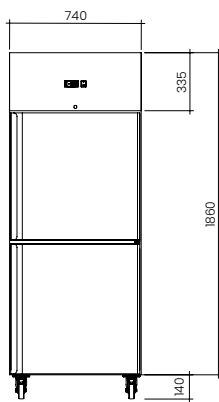

To ensure we continuously offer the best possible products, we reserve the right to modify specifications without any obligation for equipment previously or subsequently sold.

XUR G V/XUR S V/XUR SFV SERIES



XURC1200SFV / XURF1200SFV

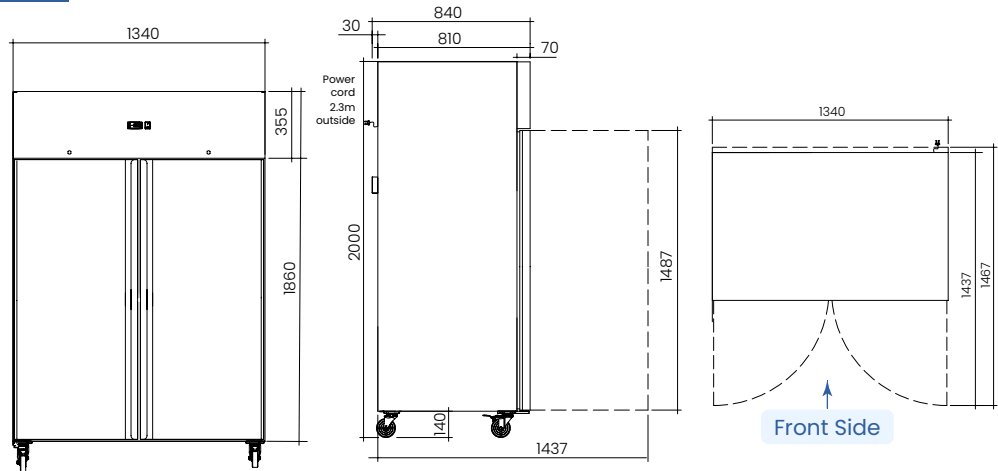

XURC1200S2V / XURF1200S2V

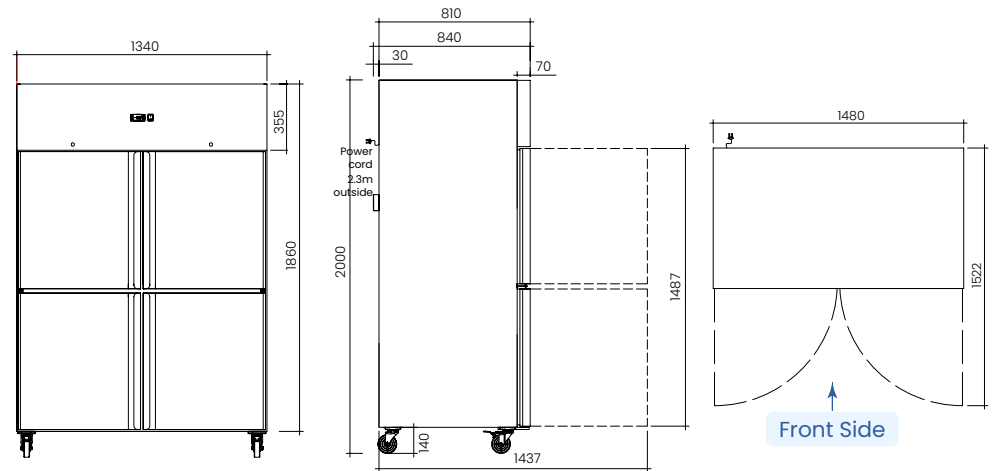

XURC1410S2V / XURF1410S2V

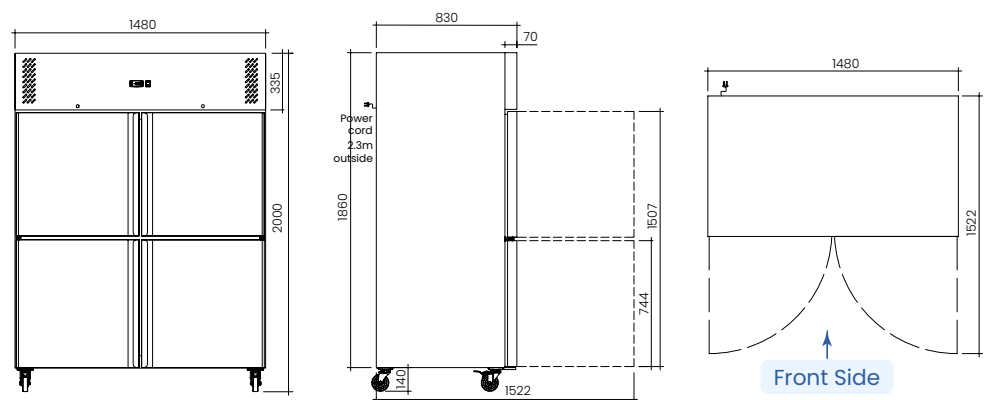

To ensure we continuously offer the best possible products, we reserve the right to modify specifications without any obligation for equipment previously or subsequently sold.

XUR G V / XUR S V / XUR SFV RANGE



XURC600G1V / XURF600G1V

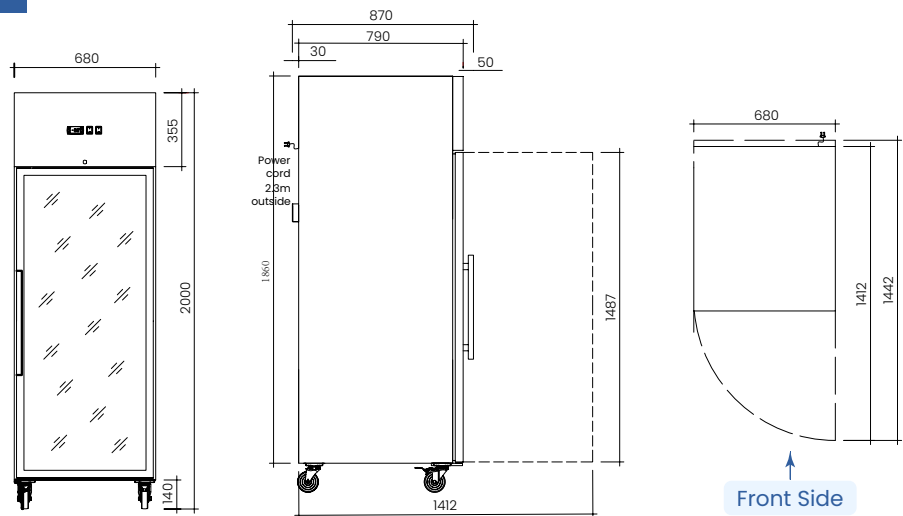

XURC1200G2V / XURF1200G2V

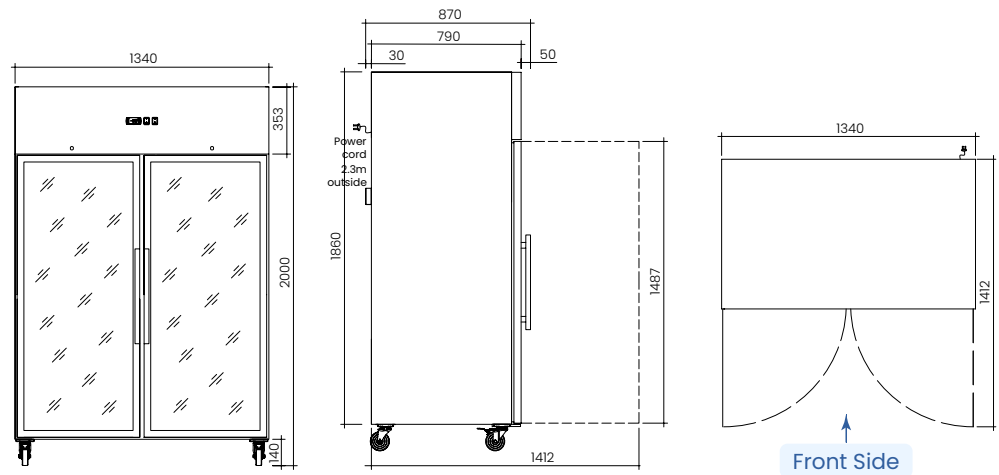

XURC1410G2V / XURF1410G2V

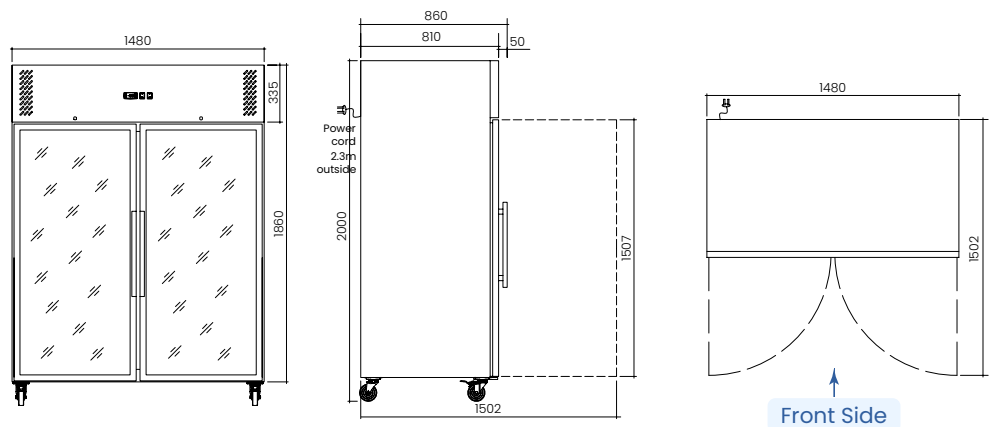



To ensure we continuously offer the best possible products, we reserve the right to modify specifications without any obligation for equipment previously or subsequently sold.

Code	Net /Gross Capacity (L)	Net Weight (kg)	Dimensions (WxDxH mm)	Climate Class	GEMS Star Rating	Temperature Range (°C)	Ambient °C/ RH%	Power (W/A)
XURC400SFV	333/429	102	680x740x2000	4	2	-2 to +8	43/60	195/10
XURF400SFV	333/429	111	680x740x2000	4	2	-22 to -18	43/60	450/10
XURC600SFV	396/618	115	680x840x2000	4	3	-2 to +8	43/60	195/10
XURF600SFV	396/618	117	680x840x2000	4	2	-22 to -18	43/60	450/10
XURC650SFV	465/650	121	740x830x2000	4	3	-2 to +8	43/60	215/10
XURF650SFV	465/650	126	740x830x2000	4	3	-22 to -18	43/60	480/10
XURC1200SFV	791/1236	167	1340x840x2000	4	3	-2 to +8	43/60	380/10
XURF1200SFV	791/1236	177	1340x840x2000	4	2	-22 to -18	43/60	700/10
XURC600SIV	388/618	115	680x840x2000	4	7	-2 to +8	43/60	210/10
XURF600SIV	388/618	126	680x840x2000	4	2	-22 to -18	43/60	465/10
XURC1200S2V	791/1236	167	1340x840x2000	4	3	-2 to +8	43/60	430/10
XURF1200S2V	791/1236	177	1340x840x2000	4	2	-22 to -18	43/60	730/10
XURC600GIV	388/618	115	680x840x2000	3	7	+2 to +8	38/60	195/10
XURF600GIV	388/618	139	680x840x2000	3	7	-18 to -15	38/60	450/10
XURC1200G2V	791/1236	182	1340x840x2000	3	6	+2 to +8	38/60	400/10
XURF1200G2V	791/1236	193	1340x840x2000	4	2	-18 to -15	38/60	700/10
XURC650SIV	450/650	121	740x830x2000	4	3	-2 to +8	43/60	310/10
XURF650SIV	450/650	126	740x830x2000	4	3	-22 to -18	43/60	495/10
XURC1410S2V	960/1410	188	1480x830x2000	4	3	-2 to +8	43/60	430/10
XURF1410S2V	960/1410	201	1480x860x2000	4	6	+2 to +8	43/60	795/10
XURC1410G2V	960/1410	208	1480x860x2000	4	3	+2 to +8	38/60	415/10
XURF1410G2V	945/1410	232	1480x860x2000	4	3	-18 to -15	38/60	865/10

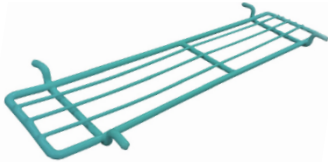
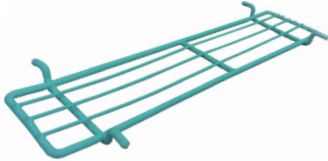
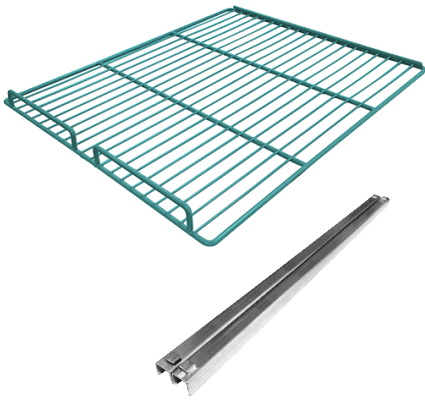

To ensure we continuously offer the best possible products, we reserve the right to modify specifications without any obligation for equipment previously or subsequently sold.

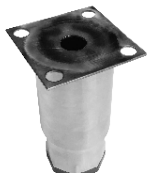
Code	Description	
Additional Shelf Set		
12502013416	Infill shelf for XURC1200G2V, XURC1200S2V, XURF1200G2V and XURF1200S2V	
12502012803	Infill shelf for XURC1410G2V, XURC1410S2V, XURF1410G2V and XURF1410S2V	
XUR-SHELFSET	Additional shelf set for upright fridge and freezer units, including one shelving and one pair of runner, suits XURC1200G2V, XURC1200S2V, XURC600G1V, XURC600S1V, XURF1200G2V, XURF1200S2V, XURF600G1V, XURF600S1V, XURC1410G2V, XURC1410S2V, XURC650G1V, XURC650S1V, XURF1410G2V, XURF1410S2V and XURF650S1V	
Optional Stainless Steel Runners		
GXE-2-1516	Runner Set for Upright Refrigeration, XURC-1200G2V, XURC1200S2V, XURC600G1V, XURC600S1V, XURF1200G2V, XURF1200S2V, XURF600G1V, XURF600S1V, XURC1410G2V, XURC1410S2V, XURC650G1V, XURC650S1V, XURF1410G2	
Legs		
12533110010	Heavy duty Stainless Steel Leg Adjustable Range 140-200mm (per pc)	



Full Glass and Solid Door Upright Fridges & Freezers

XUR G V/XUR S V/XUR SFV RANGE

XURC400SFV, XURF400SFV, XURC600SFV, XURF600SFV,
 XURC650SFV, XURF650SFV, XURC1200SFV, XURF1200SFV,
 XURC600SIV, XURF600SIV, XURC1200S2V, XURF1200S2V,
 XURC650SIV, XURF650SIV, XURC1410S2V, XURF1410S2V,
 XURC600GIV, XURF600GIV, XURC1200G2V, XURF1200G2V,
 XURC1410G2V, XURF1410G2V



ENERGY RATING
 THE MORE STARS
 THE MORE SAVINGS

