

YXD-1AE EXPLODED DIAGRAM

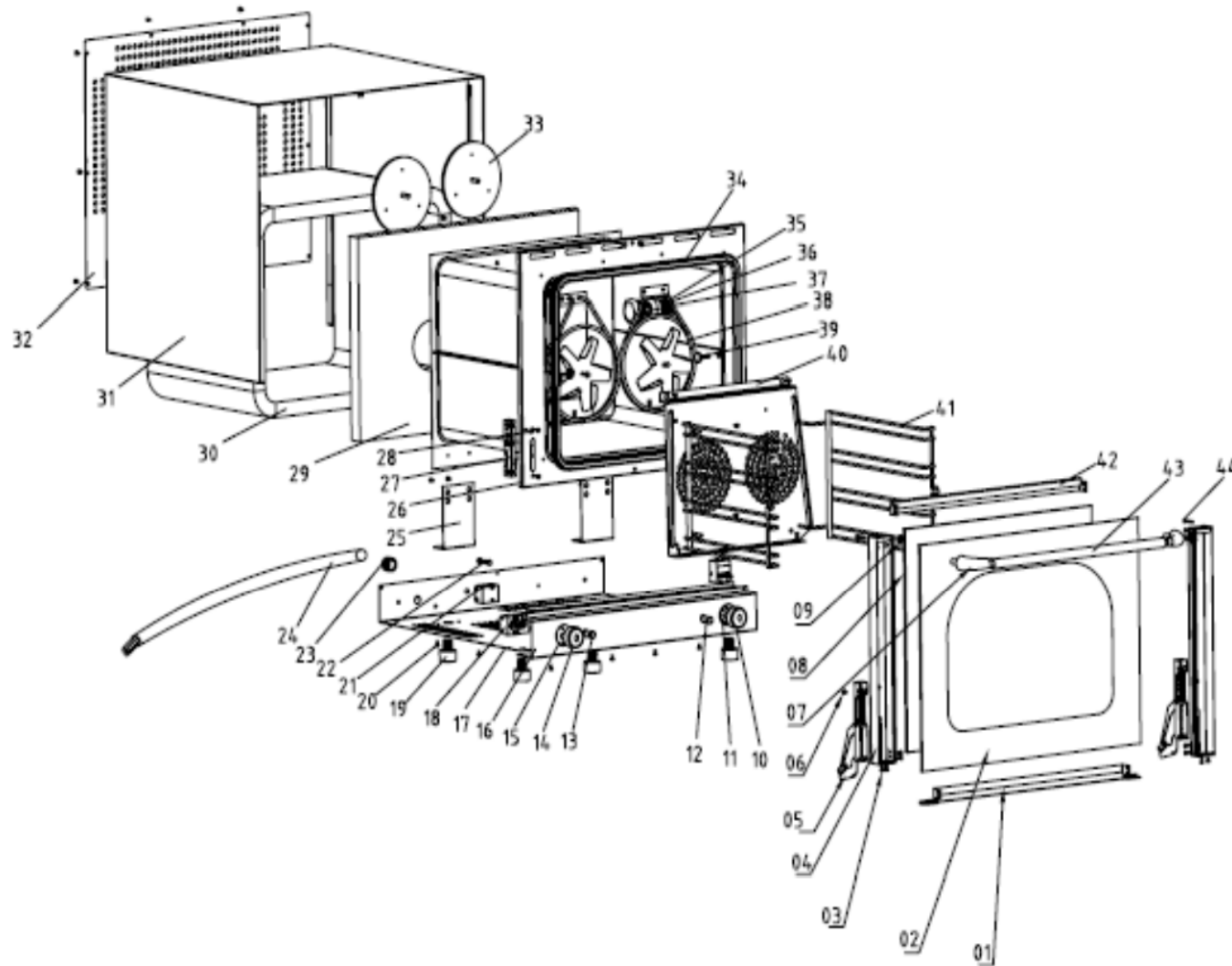

YXD-1AE PARTS LIST

Item	FHE Part Code	Description	Qty	Remark
1	20207017005	Door Bottom Beam	1	
2*	70201005055L	Exterior Door Glass With Black Square Border 578mm X 449mm	1	Assembly see code 801005003006
3		Screw	10	
4	802005013003	Left/Right Side Plate For Door	2	
5*	YXD-3A-05A	Door Hinge 302040263/70200402637	2	
6		Sunk Screw	8	
7	YXD-1AE-07	Holder For Door Handle 302070016/70200700164	2	
8*	YXD-1AE-08	Inner Door Glass 442mm X 492mm 302100023/70201000237	1	
9		Tapping Screw	10	
10*	70101100346	Thermostat Knob For Back Heating Elements	2	
11	YXD-1AE-10	Thermostat Knob Base 301110022/70101100228	1	
12*	YXD-1AE-12	Green Indicator 220V Φ13 301130015/70101300155	1	
13*	YXD-1A-GREEM LAMP	Green Indicating Lamp 301130013/70101300137	1	
14*	YXD-1A-08	Timer Knob 301110037/70101100373	1	
15*	YXD-1AE-15	Dial for Timer Knob 301110020/70101100200	1	
16	20207017015	Control Panel	1	
17	20207017013	Bottom Plate	1	

YXD-1AE PARTS LIST

Item	FHE Part Code	Description	Qty	Remark
18*	YXD-1AE-18	Timer 120 Min 301120011/70101200119	1	
19	70200900228	Rubber Foot 302090022	4	
20		Screw	12	
21*	70100301982L	Temperature Limiter 360°C	1	
22		Ground screw	1	
23	301070078	Power Cord Sleeve	1	
24	YXD-1AE-PC	Power Cord	1	
25	20207017011	Foot Support Plate	2	
26	20107017001	Chamber Assembly	1	
27*	70200402664	New Version Hinge Runner	2	
28		Screw	12	
29	YXD-1AE-RIC	Rear Insulation Cotton	1	
30	YXD-1AE-CIC	Chamber Insulation Cotton	1	
31		Skirt Panel	1	
32	20207017014	Rear Plate	1	
33*	YXD-3A-35	Fan Motor 301010131/70100101319	1	
34*	YXD-1AE-34A	Door Seal Black 5 X 4 302020055/70200200555	1	
35	YXD-1AE-35	Rubber Ring For Lamp Holder 302020010/70200200100	1	

FHE After Sales Service & Support (AU)
 Phone: 1300887055
 Spares Email: spares@fedservices.com.au

FHE After Sales Service & Support (NZ)
 Phone: 09 415 6471
 Service Email: service@fedproducts.co.nz

YXD-1AE PARTS LIST

Item	FHE Part Code	Description	Qty	Remark
36*	YXD-1AE-36	Lamp 301130048/70101300482	1	Assembly see code YXD-1AE-LA
37	YXD-8A-33	Lamp Base 301130038/70101300382	1	Assembly see code YXD-1AE-LA
38*	301040094	Heating Element 70100400946 230v/50hz 1.26kw		
39	302200160	Screw 70202001600	1	
40	802005003004	Draught Guard	1	
41*	302110045	Shelf 370mm X 245mm 70201100455	1	
42	20207017006	Door Upper Beam	1	
43*	20207017018	Door Handle	1	
44		M4*20 screw	10	
	YXD-1A-4A	Tray 435mm X 315mm 302120029 70201200291		Assembly see code TDE-4C-SS
	YXD-1A-4B	Wire Rack 435mm X 315mm 302110158/70201101582		Assembly see code TDE-4C-SS
	Component	TDE-4C-SS		Shelf Set 435mm X 315mm incl 1 PCS of 70201200291 and 3 PCS of 70201101582 Included in YXD-1A-4A and YXD-1A-4B
	Component	801005003006		Complete Door (Square Viewing Window) 20107017002+302100019/70201005055L 1 Included in Item 2
	Component	YXD-1AE-LA		Lamp and Holder 70101300482+70101300382 Included in Item 36 & 37
		YXD-1AE-11		Thermostat 50-300°C 301030020/70100300200
		YXD-1A-34		DOOR HANDLE

YXD-1AE PARTS LIST

Item	FHE Part Code	Description	Qty	Remark
	YXD-1A-35A	Door Springs		
	YXD-1AE-21	Temperature Limiter 301030042		

*Wearable parts